

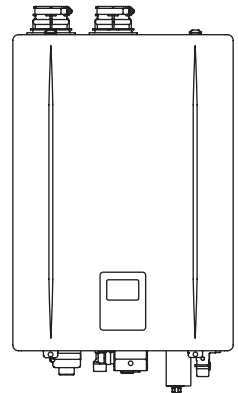

CONDENSING TANKLESS GAS WATER HEATER

Installation Manual

Model : NCC199CDV (GQ-C3261WZ-FF-1 US)



⚠ DANGER

Installing Water Heaters with Propane (LP) Gas
 THIS WATER HEATER IS EQUIPPED FOR NATURAL GAS.
 This water heater is equipped with orifices for the natural gas.
 Orifice necessary for Propane (LP) conversion is provided with the water heater. For conversion to Propane (LP) gas, follow the installation guide in the conversion kit, replace the parts correctly.

⚠ WARNING

If the information in these instructions is not followed exactly, a fire or explosion may result causing property damage, personal injury or death.

- Do not store or use gasoline or other flammable vapors and liquids in the vicinity of this or any other appliance.
- **WHAT TO DO IF YOU SMELL GAS**
 - Do not try to light any appliance.
 - Do not touch any electrical switch; do not use any phone in your building.
 - Immediately call your gas supplier from a neighbor's phone. Follow the gas supplier's instructions.
 - If you cannot reach your gas supplier, call the fire department.
- Installation and service must be performed by a qualified installer, service agency or the gas supplier.

⚠ CAUTION

Requests to installers

- In order to use the water heater safely, read this installation manual carefully and follow the installation instructions.
- Failures and damage caused by erroneous work or work not performed as instructed in this manual are not covered by the Noritz America Limited Warranty.
- When using remote controller, refer to the installation manual provided with the remote controller.
- Confirm that the installation was done properly in accordance with this installation manual upon completion.
- After completing installation, either place this installation manual and owner's guide (with warranty registration information included) in a plastic pouch and attach it to the side of the water heater (or the inside of the pipe cover or recess box if applicable) or hand it to the customer to retain for future reference. For the warranty conditions and limitations, see the owner's guide.

FOR USE IN COMMERCIAL OR MANUFACTURED HOME APPLICATIONS.

Installation must conform with local codes, or in the absence of local codes, the National Fuel Gas Code, ANSI Z223.1 / NFPA 54 (latest edition) and/or the Natural Gas and Propane Installation Code CSA B149.1 (latest edition).

When applicable, installation must conform with the Manufactured Home Construction and Safety Standard, Title 24 CFR, Part 3280 or the Canadian Standard CAN/CSA-Z240 MH Mobile Homes, Series M86.

Noritz America reserves the right to discontinue, or change at any time, the designs and/or specifications of its products without notice.

Contact Noritz America at 1-866-766-7489 if you have any questions or concerns.



Certified to
NSF/ANSI/CAN 372

- Certified to NSF/ANSI/CAN 372 for lead free
- Certified to NSF/ANSI 5 for Food Equipment



AIRI CERTIFIED
www.airidirectory.org

Low NOx Approved by SCAQMD
14 ng/J or 20 ppm
(Natural Gas Only)

NORITZ America Corporation

SBB81M4-1
Rev. 10/25



Contents

1	Before Installation	3
2	About the Water Heater	5
2.1	Included Accessories	5
2.2	Optional Accessories	5
2.3	Specifications	7
2.4	Dimensions	8
2.5	External View	10
3	Choosing an Installation Location	11
4	Installation Clearances	13
4.1	Indoor Installation	13
4.2	Outdoor Installation	14
4.3	For Quick Connect Multi-System.....	14
5	Installing the Water Heater	15
5.1	Mounting the Water Heater to the Wall	15
5.2	Adjusting for Elevations Above 1,000 ft.....	16
5.3	Filling the Condensate Container with Water	16
6	Venting the Water Heater	16
6.1	Venting Installation Sequence	16
6.2	General Requirements.....	17
6.3	Selecting a Vent Type.....	20
6.4	Vent Pipe Installation (Direct Vent)..	21
6.5	Vent Pipe Installation (Non-Direct Vent)	27
6.6	Outdoor Installation	31
7	Connecting the Gas Supply	31
8	Connecting the Water Supply	36
8.1	Installation	36
8.2	Water Treatment	38
9	Connecting the Condensate Drain	39
10	Connecting Electricity	41
10.1	Water Heater	41
10.2	Remote Controller (When connecting a remote controller)	42
10.3	Recirculation Pump.....	43
10.4	Quick Connect Cord.....	44
10.5	Condensate Pump Safety Switch Wiring	45
10.6	Carbon Monoxide Detector Wiring..	45
11	Water Heater Settings	46
11.1	Using the Operation Panel	46
11.2	Using the App “EZ Start Plus®”	48
12	Trial Operation	52
13	Checklist after Installation	55
14	Plumbing Applications	57
15	Installation of the Quick Connect Multi-System	59
16	Installation of the Multi-System	62
16.1	With a System Controller (SC-401-6M).....	62
16.2	With a System Controller Unit (SCU-401-12M, SCU-401-24M)	66
17	Maintenance	70
17.1	Periodic Check	70
17.2	Procedure for Flushing the Heat Exchanger	70

1 Before Installation

Hazards that may cause accidents during installation and use are divided into the following four categories. Closely observe these warnings, as they are critical to your safety.

⚠ DANGER

Indicates an imminently hazardous situation that, if not avoided, will result in death or serious injury.

⚠ WARNING

Indicates a potentially hazardous situation that, if not avoided, could result in death or serious injury.

⚠ CAUTION

Indicates a potentially hazardous situation that, if not avoided, may result in minor or moderate injury.

NOTICE

Indicates a potentially hazardous situation that, if not avoided, may result in property damage.

⚠ DANGER

Checkup

Check the fixing brackets and vent pipe yearly for damage or wear. Replace if necessary.

⚠ WARNING

When replacing the vent pipe

The vent system will probably need to be replaced when this appliance is being installed. Only use vent materials that are specified in this installation manual for use with this appliance. Refer to the “Venting the Water Heater” section for details. If a PVC, CPVC, or Category IV listed pipe is already installed, check for punctures, cracks, or blockages and consult with the vent pipe manufacturer before reusing. Improper venting may result in fires, property damage or exposure to carbon monoxide.

When installing in snowy areas

If this product will be installed in an area that is known to experience heavy snowfall, protect the vent termination from blockage by snow drifts or damage from snow falling off roofs.

Check the specifications on the rating plate

- Confirm that the correct gas type is displayed on the rating plate or the gas conversion sticker.
- Make sure that the gas supply line is sized for 199,900 Btu/h.

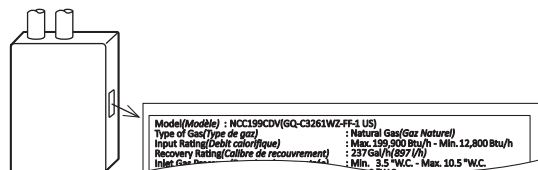

Check the power

The required power supply is 120 VAC at 60 Hz. Using incorrect voltage may result in fire or electric shock.

Use extreme caution if using with a solar pre-heater

Using this appliance with a solar pre-heater can lead to unpredictable output temperatures and possibly scalding. To ensure outlet temperatures do not exceed 120°F (49°C) at faucets, a mixing valve must be installed.

Do not use a solar pre-heater with the quick connect multi-system because the system may not operate properly.

When installing in a mobile home

- Verify that the gas supply matches the gas type listed on the rating plate. If a gas conversion is required, follow the instructions listed in the installation guide included in the conversion kit.
- If this product will be installed indoors, do not use the SV conversion kit (SV-CK-2-1). Make sure to follow all clearance and venting requirements outlined in this manual.



WARNING: This product may expose you to chemicals, including lead, lead compounds and carbon disulfide, which are known by the State of California to cause cancer and birth defects or other reproductive harm. For more information, see www.P65Warnings.ca.gov.

⚠ CAUTION

Do not use for purposes other than those specified

Do not use this appliance for purposes other than increasing the temperature of the water supply, as accidents may occur as a result.

Check water supply quality

If the water supply has a hardness greater than 12 grains per gallon (200 mg/L) or is, acidic or otherwise impure, treat the water with approved methods in order to ensure full warranty coverage.

NOTICE

- This appliance can be used for heating potable water and for space heating. However, it cannot be used solely for space heating purposes.
- If any part of this appliance becomes submerged in water, stop using this appliance. Immediately call a qualified service technician to inspect the appliance and replace any part of the control system or gas control that has been submerged in water.

terminal for the horizontally vented gas fueled heating appliance or equipment. The sign shall read, in print size no less than one-half (1/2) in. in size, "GAS VENT DIRECTLY BELOW. KEEP CLEAR OF ALL OBSTRUCTIONS".

- EXEMPTIONS to the requirements listed above:
 - The above requirements do not apply if the exhaust vent termination is seven (7) ft or more above finished grade in the area of the venting, including but not limited to decks and porches.
 - The above requirements do not apply to a product installed in a room or structure separate from the dwelling, building or structure used in whole or in part for residential purposes.
- This installation manual shall remain with the product at the completion of the installation.

See the latest edition of Massachusetts Code 248 CMR for complete verbiage and also for additional (non-vent related) requirements (248 CMR is available online). If your installation is NOT in Massachusetts, please see your authority of jurisdiction for requirements that may be in effect in your area. In the absence of such requirements, follow the National Fuel Gas Code, ANSI Z223.1/ NFPA 54 and/or CAN/CSA B149.1, Natural Gas and Propane Installation Code.

Please read if installing in Massachusetts

Massachusetts code requires manufacturers of side wall vented products to provide the following information:

- A hard wired carbon monoxide detector with an alarm and battery back-up must be installed on the floor level where the gas equipment is to be installed and on each additional level of the dwelling, building or structure served by the side wall horizontal vented gas fueled equipment.
- In the event that the side wall horizontally vented gas fueled equipment is installed in a crawl space or an attic, the hard wired carbon monoxide detector with alarm and battery back-up may be installed on the next adjacent floor level.
- Detector(s) must be installed by qualified licensed professionals.
- APPROVED CARBON MONOXIDE DETECTORS: Each carbon monoxide detector shall comply with NFPA 720 and be ANSI/UL 2034 listed and IAS certified.
- SIGNAGE: A metal or plastic identification plate shall be permanently mounted to the exterior of the building at a minimum height of eight (8) ft above grade directly in line with the exhaust vent

2 About the Water Heater

2.1 Included Accessories

The following accessories are included with the water heater. Check for any missing items before starting installation.

Anchoring Screws



Owner's Guide, Installation Manual (this document)

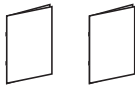

Wall Mounting Bracket

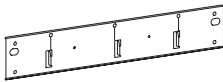

LP Gas Conversion Kit



2.2 Optional Accessories

The accessories listed below are not included with the water heater, but they may be necessary for installation.

NOTE Additional vent pieces are available. Consult the latest product catalog for details.

Quick Connect Cord [QC-2]



Isolation Valves (includes pressure relief valve) [IK-WV-200-X]

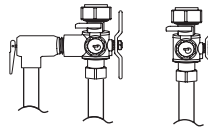

Isolation valves are necessary for flushing the heat exchanger. They allow for easy flushing and troubleshooting of the system.

PVC Concentric Termination 2 in. (50 mm): [PVC-2CT] 3 in. (75 mm): [PVC-3CT]

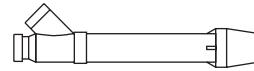

2 in. SV Conversion Kit [SV-CK-2-1]

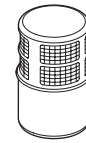

Outdoor Vent Cap [VC-6-1]

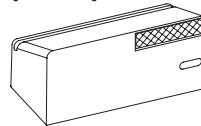

Not approved for use in Canada.

Bird Screen for 2 in. (50 mm) PVC [VT2-PVCS]



Bird Screen for 3 in. (75 mm) PVC [VT3-PVCS]



Bird Screen for 4 in. (100 mm) PVC [VT4-PVCS]

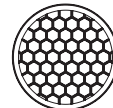

3 in. (75 mm) / 4 in. (100 mm) Horizontal Hood Termination [PVT-HL]



Not approved for use in Canada.

Universal Concentric Vent Kit
[PVC-UCVK]



Low Profile Termination Kit
2 in.: [PVC-2LPT]
3 in.: [PVC-3LPT]



ULC S636 / UL 1738
certified for use in both
Canada and USA

Plastic Rain Cap
[PRC-1]



Not approved for use in
Canada.

System Controller
[SC-401-6M]

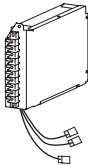

A remote controller and
remote controller cords are
required.

System Controller Unit
[SCU-401-12M, SCU-401-24M]

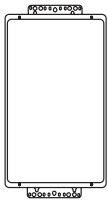

A remote controller and
remote controller cords are
required.

Pipe Cover
[PC-11S]

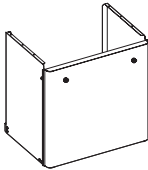

Neutralizer
[NC-1W]
(For 1 water heater)

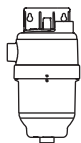

Neutralizer
[NT20A]
(For up to 16 water heaters)

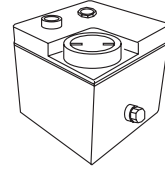

Noritz Connect Wireless Adapter
NWC-ADAPTER
[NAW-1 US]

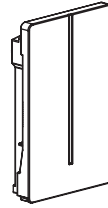

Noritz Connect Wireless
Adapter enables users to:

- Control the water
heater remotely (turn
power on/off, adjust set
temperature)

A remote controller is
required.
For more information, visit
the Noritz America website
(<http://wifi.noritz.com/>).

Remote Controller
[RC-9018M]

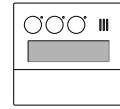

Remote Controller Cord (10 ft (3 m))
[RC-CORD10]

Remote Controller Cord (26 ft (7.9 m))
[RC-CORD26]



Noritz Recirculation System
[RPK-EXT-P]

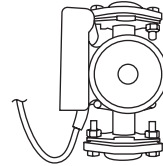

Scale Shield Water Treatment
[SS-HB-3]



This product is designed
for single unit installations
only. If multiple water
heaters are installed,
contact Noritz America for
sizing.

Descale Kit
[DACL-KIT]

2.3 Specifications

- Specifications may be changed without prior notice.
- The capacity may differ slightly depending on the water pressure, piping conditions, and water temperature.

Item		Specification
Model Name		NCC199CDV (GQ-C3261WZ-FF-1 US)
Type	Installation	Indoor / Outdoor Wall mounted
	Air Supply / Exhaust	Power Vented
Ignition		Direct Ignition
Operating Pressure		15-150 psi (Recommended 50 to 80 psi for maximum performance)
Minimum Activation Flow Rate*		0.4 GPM (1.5 L/min)
Minimum Operating Flow Rate*		0.26 GPM (1.0 L/min)
Dimensions (Height) × (Width) × (Depth)		26.1 in. (662 mm) × 18.1 in. (461 mm) × 11.8 in. (300 mm)
Weight		62 lbs. (28 kg)
Water Holding Capacity		0.71 gal (2.7 L)
Connection Sizes	Water Inlet	NPT 3/4 in.
	Hot Water Outlet	NPT 3/4 in.
	Gas Inlet	NPT 3/4 in.
	Condensate Drain	NPT 1/2 in.
Power Supply	Supply	120 VAC (60 Hz)
	Consumption (NG / Propane (LP))	105 W / 108 W
	Freeze Prevention	114 W
	Maximum Current	4 Amps
Gas Consumption	Maximum	199,900 Btu/h
	Minimum	12,800 Btu/h
Maximum Hot Water Capacity (45°F (25°C) Rise)		8.7 GPM (33 L/min)
Capacity Range		0.4-11.1 GPM (1.5-42 L/min)
Temperature Settings	°F Mode	100-150°F (in 5°F intervals), 160°F, 170°F, 185°F (14 options)
	°C Mode	37-48°C (in 1°C intervals), 50-85°C (in 5°C intervals) (20 options)
Materials	Casing	Front Cover, Side/Top Plate: Hot-dipped zinc-aluminum-magnesium-alloy-coated steel with Polyester Coating Back, Bottom Plate: Hot-dipped zinc-aluminum-magnesium-alloy-coated steel without Coating
	Flue Collar	Polypropylene
	Primary Heat Exchanger	Stainless Steel Sheeting, Stainless Steel Tubing
	Secondary Heat Exchanger	Stainless Steel Sheeting, Stainless Steel Tubing
Safety Devices		Flame Rod, High Limit Switch, Lightning Protection Device (ZNR), Freezing Prevention Device, Fan Rotation Detector, Thermal Fuse
Included Accessories		Anchoring Screws, Wall Mounting Bracket, LP Gas Conversion Kit

* Minimum flow rate may change by setting temperature and water temperature.

2.4 Dimensions

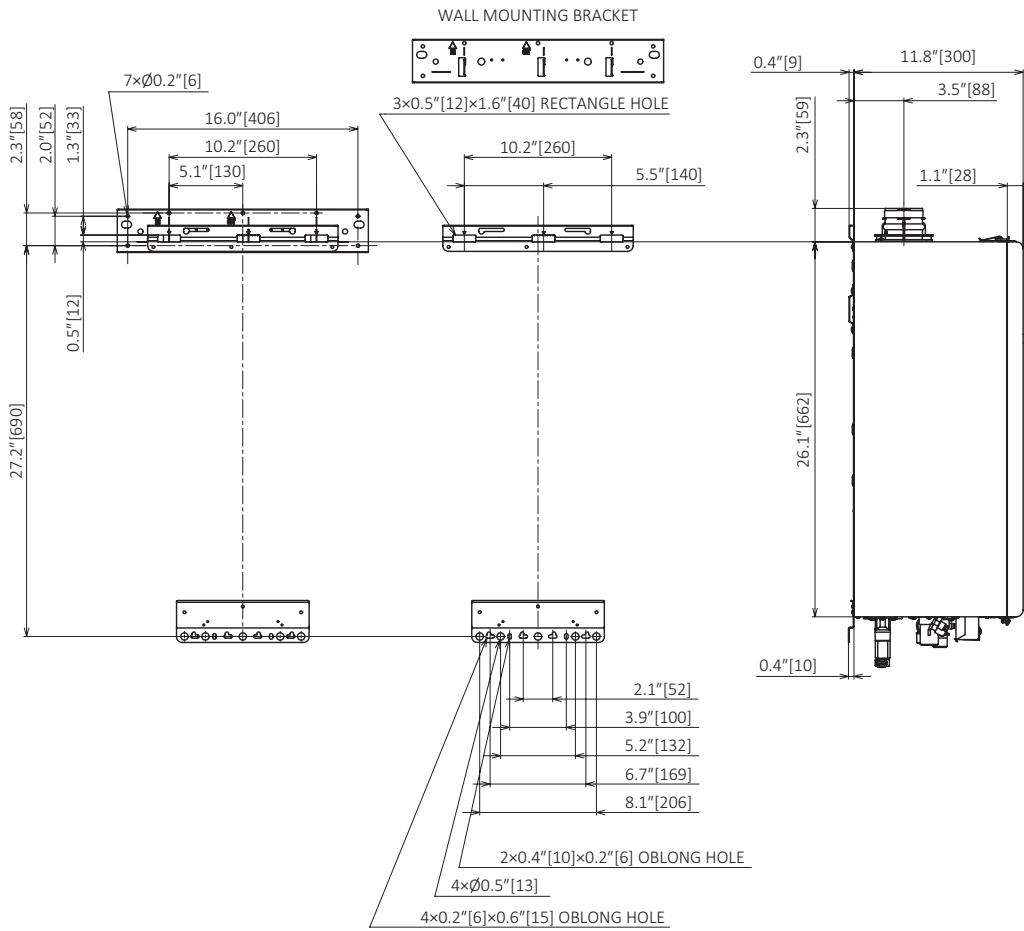

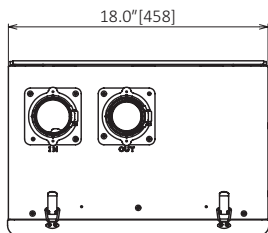

(VIEW FROM BOTTOM)

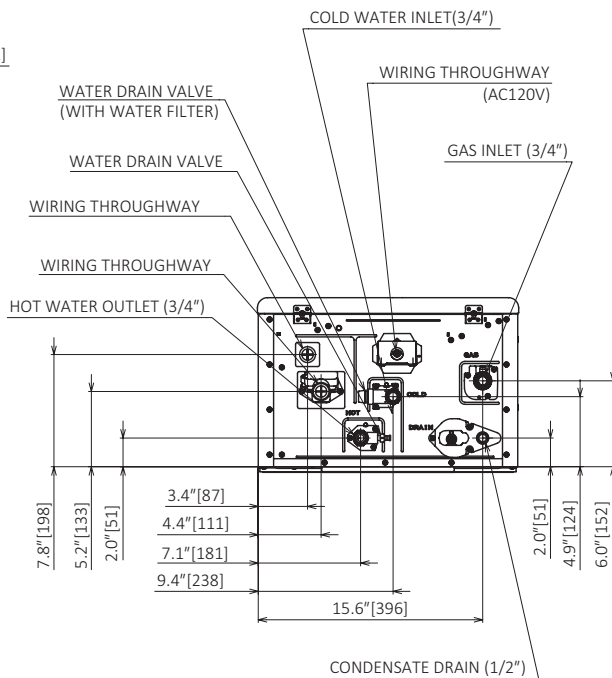
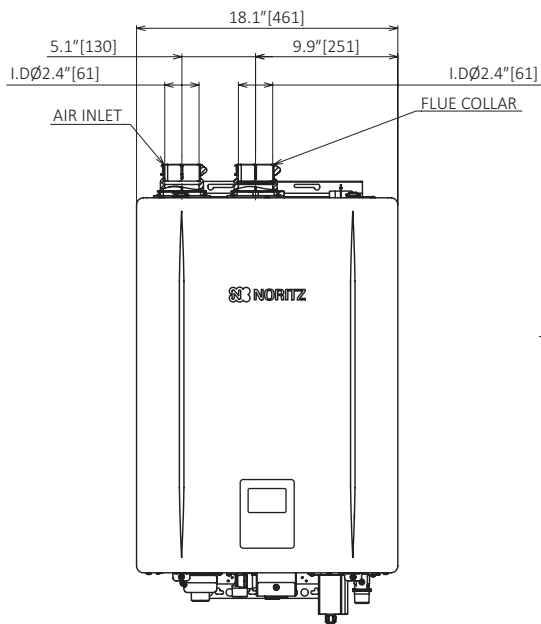

HEIGHT OF EACH FITTING FROM BOTTOM OF CASE

HOT WATER OUTLET	1.8" [45]
COLD WATER INLET	1.9" [49]
CONDENSATE DRAIN	1.7" [42]
GAS INLET	2.2" [56]

2.5 External View

Indoor Installation

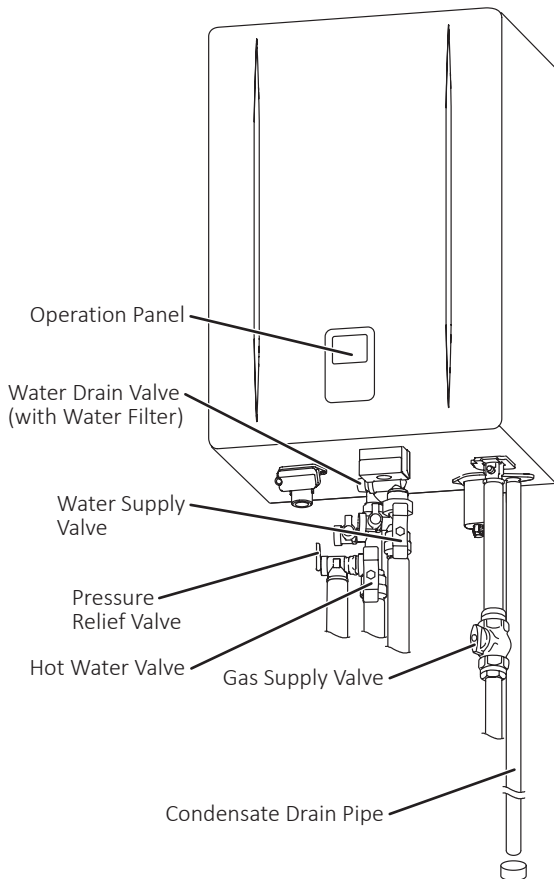

Outdoor Installation

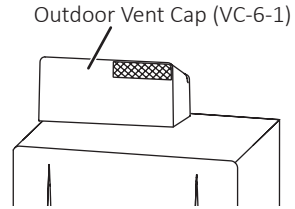

The exterior view of air intake side ("Intake Pipe") may be different due to the installed item.

(Example of direct vent installation)

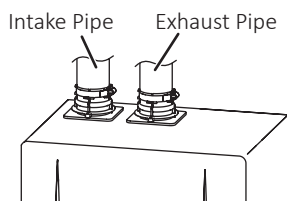

(Example of non-direct vent installation)

2 in. SV Conversion Kit (SV-CK-2-1)

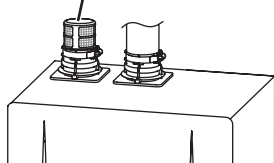

3 Choosing an Installation Location

⚠ DANGER

Locate the vent terminal and make sure there are no obstructions around the vent termination that may block it and cause exhaust to accumulate. Do not enclose the termination with corrugated metal or other materials. Carbon monoxide poisoning or fire may occur as a result.

⚠ WARNING

- Avoid places with a high risk of fire, such as places where gasoline, benzene or adhesives are handled, and places in which corrosive gases (ammonia, chlorine, sulfur, ethylene compounds, acids, etc.) are present. Installing this appliance in these places may result in a fire or explosion, causing in property damage, personal injury or death.
- Avoid installing in places where dust or debris will accumulate. Dust may accumulate and reduce the performance of the fan. This can result in incomplete combustion.
- Avoid installing in places where chemical sprays (e.g. hair spray or spray detergent) are used. Ignition failure or malfunction may occur as a result.
- Do not install this water heater in a recreational vehicle or on a boat as this may be a carbon monoxide poisoning hazard.
- The manufacturer does not recommend installing the water heater in an attic due to safety issues.
If you install the water heater in an attic:
 - Make sure the appliance will have enough combustion air and proper ventilation.
 - Keep the area around the water heater clean. Dust may accumulate and reduce the performance of the fan. This can result in incomplete combustion.
 - A drain pan or other means of protection against water damage is required to be installed under the water heater in case of leaks.

⚠ CAUTION

Do not install in the following places

- Locations with obstructions or stagnant air.
- Near staircases or emergency exits.
- Locations where items may fall on the water heater.
- On common walls between apartments, as the appliance will make some operational noises while it is running.

Consideration of surroundings

- Do not install the water heater where the exhaust will come into or contact with outer walls, other walls or materials that are not resistant to heat. Also consider trees and animals in the vicinity. The heat and moisture from the water heater may cause discoloration of walls and resinous materials, or corrosion of aluminum materials.
- Do not direct the vent termination towards a window or any other structure with glass or wired glass facing the termination.
- Make sure that noise and exhaust gas will not affect neighbors.
- If the appliance is installed in a location with very high humidity, condensate may form inside the appliance, which may cause incomplete combustion, damage to the electrical components, or electric leakage.

Install according to regulations and manual

- Install the water heater in an area with sufficient clearances for combustible and non-combustible construction. Consult the rating plate on the appliance for the required clearances.
- The water heater must be installed according to this manual.
- Before installing, make sure that the exhaust flue termination will have the proper clearances according to the National Fuel Gas Code (ANSI Z223.1- latest edition) or the Natural Gas and Propane Installation Code (CSA B149.1).

Installation in the vicinity of gas ranges, stoves, fans, and range hoods

- Avoid installation above gas ranges or stoves.
- Avoid installation between a kitchen fan and stove. If installing in an area where oily fumes or large quantities of steam are present, take measures to prevent the fumes and steam from entering the appliance.

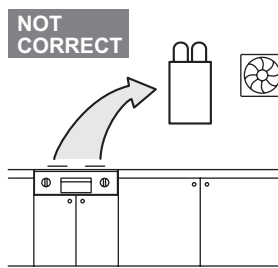

- Install in a location where the exhaust gas flow will not be affected by fans or range hoods.

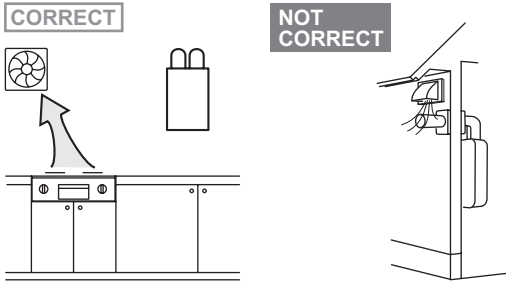

NOTICE

- Place the appliance in an area where it can be easily accessed for maintenance and repair.
- Do not install the water heater in a location where the appliance will be exposed to excessive winds.
- Install the appliance in an area where leakage from the appliance or connections will not result in damage to the area adjacent to the appliance or to the lower floors of the structure. If such installation locations cannot be avoided, a suitable drain pan with adequately drainage must be installed under the appliance. The pan must not restrict combustion air flow.
- As with any water heating appliance, the potential for leakage at some time during the life of the product does exist. The manufacturer accepts no responsibility for any water damage that may occur.
- Water quality:
If this water heater will be installed in a location where the hardness of the supply water is high, scale build-up may cause damage to the heat exchanger. Perform suggested treatment and maintenance measures according to "8.2 Water Treatment".
Damage to the water heater as a result of the following is not covered by the Noritz America Limited Warranty.
 - Water with a hardness exceeding 12 gpg (200 mg/L)

- Poor water quality (see the following table)

Contaminant	Maximum Allowable Level
Total Hardness*	200 mg/L (12 gpg)
Aluminum	0.05 to 0.2 mg/L
Chlorides	250 mg/L
Copper	1.0 mg/L
Iron	0.3 mg/L
Manganese	0.05 mg/L
pH	6.5-8.5
Total Dissolved Solids	500 mg/L
Zinc	5 mg/L
Sulfates	250 mg/L
Residual chlorine*	4 mg/L

Source: EPA National Secondary Drinking Water Regulations (40 CFR Part 143.3)

* Maximum limit suggested by Noritz.

- NOTE** Consult with the customer about the location of installation.

State Installation Requirements

State of California: The water heater must be braced, anchored or strapped to avoid moving during an earthquake. Contact local utilities for code requirements in your area or call 1-866-766-7489 and request instructions.

Commonwealth of Massachusetts:

- 1) This water heater can only be used in outdoor applications if the usage is restricted to summertime usage exclusively.
- 2) The water heater can be used for hot water only and not in a combination of domestic and space heating.

For venting manufacturers requirements, see the Noritz America website (www.noritz.com).

4 Installation Clearances

⚠ WARNING

Install in accordance with relevant building and mechanical codes, as well as any local, state, or national regulations, or in the absence of local and state codes, refer to National Fuel Gas Code ANSI Z223.1 / NFPA 54 (latest edition). In Canada, see the Natural Gas and Propane Installation Code CSA B149.1 (latest edition) for detailed requirements.

4.1 Indoor Installation

Required Clearances from the Water Heater

Maintain these clearances from both combustible and non-combustible materials.

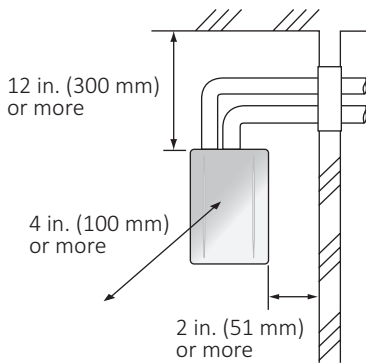

Space for Inspection/Repair

The following minimum clearances should be met to provide enough space for inspection and repair.

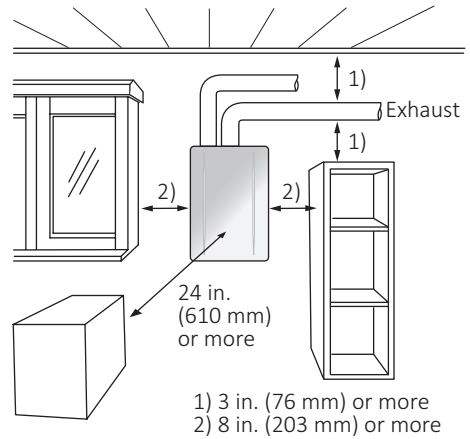

Cooking Equipment

If an indoor air supply will be utilized and the water heater will be installed in the vicinity of a permanent kitchen range or stove that may generate steam containing fats or oils, use a dividing plate or other measure to ensure that the water heater is not exposed to air containing such impurities.

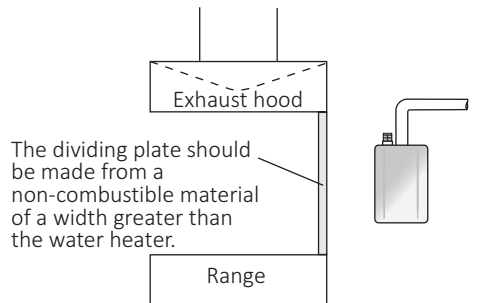

4.2 Outdoor Installation

Required Clearances from the Water Heater

Maintain these clearances from both combustible and non-combustible materials.

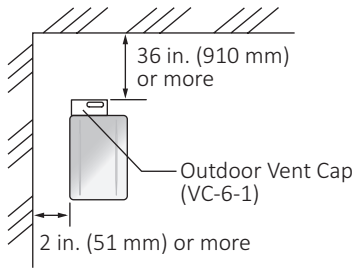
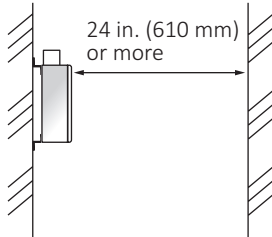

4.3 For Quick Connect Multi-System

The quick connect cord is 6 ft (1.8 m) long. Install the water heaters 2-18 in. (51-457 mm) apart from each other to ensure the cord will be able to reach between the water heaters.

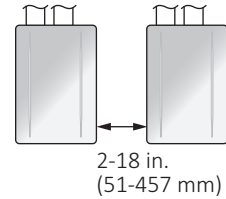

Surrounding Area

When installing the water heater in a common side corridor

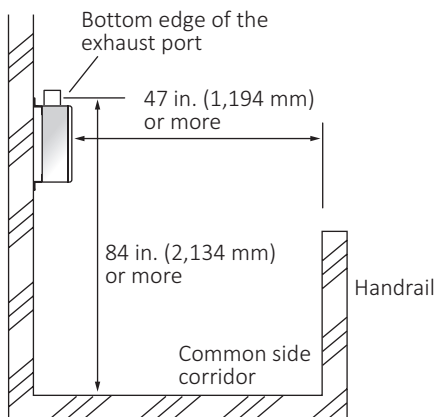

5 Installing the Water Heater

5.1 Mounting the Water Heater to the Wall

⚠ WARNING

Do not drop or apply unnecessary force to the appliance when installing. Internal parts may be damaged and may become highly dangerous.

⚠ CAUTION

- Protect your hands with gloves and take care to avoid injury.
- Be careful not to hit electrical wiring or gas or water piping while drilling holes.

NOTICE

- The weight of the appliance will be applied to the wall. If the strength of the wall is not sufficient, reinforcement must be added to prevent the transfer of vibration.
- Install the appliance on a vertical wall and ensure that it is level.

1. Ensure that the wall mounting bracket is level. Drill holes for the wall mounting bracket and affix the wall mounting bracket securely to the wall with 5 screws. Finally, make sure the bracket can support the weight of the water heater.

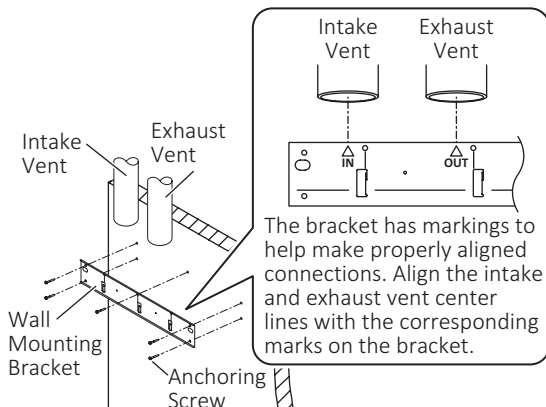

2. Hang the water heater on the wall mounting bracket.

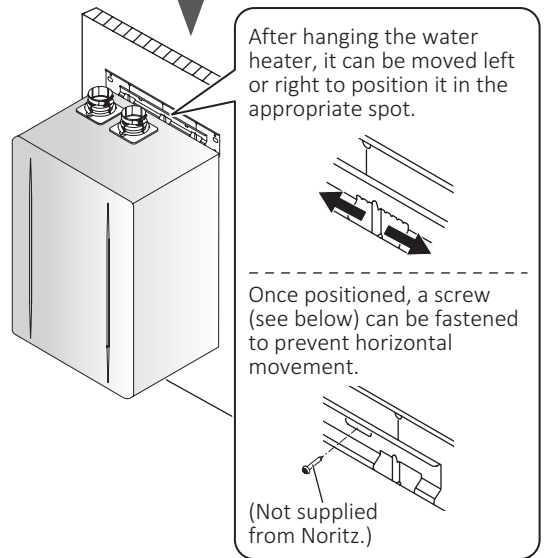
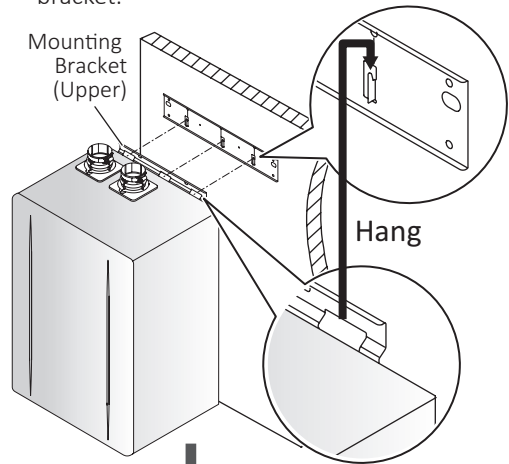

3. Affix the mounting bracket (lower) to the wall by 2 screws.

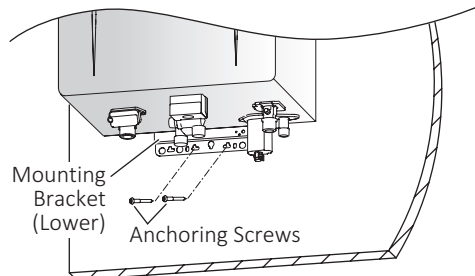

5.2 Adjusting for Elevations Above 1,000 ft

Change the settings according to elevation, if this water heater is installed at an elevation of 1,000 ft (305 m) or higher. For how to configure the settings, see page 47 when using the operation panel, or see page 50 when using the app.

NOTE The unit will derate by 4% for each 1,000 ft (305 m) of elevation.

5.3 Filling the Condensate Container with Water

⚠ DANGER

Make sure that you fill the condensate container with water before using the water heater for the first time.

This is to prevent dangerous exhaust gases from entering the building.

Failure to fill the condensate container could result in severe personal injury or death.

Follow the procedure described below to ensure that the condensate container is filled with water.

Fill the condensate container by pouring approx. 10 oz. (280 mL) of water into the exhaust flue on the top of the water heater as illustrated below.

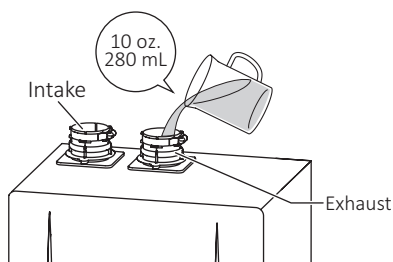

If the vent pipe has already been installed: After installing the condensate drain pipe, make sure that the area around the water heater is well ventilated. Open a window or a door if necessary. Then operate the water heater and check that condensate comes out of the condensate drain pipe.

(During normal use of the water heater, condensate will usually begin to discharge from the condensate drain pipe within 15 minutes of use, but it may take longer depending on the season and/or installation site conditions.)

6 Venting the Water Heater

⚠ WARNING

Carbon monoxide poisoning

Follow all vent system requirements in accordance with relevant local or state regulations, or, in the absence of local or state code, if in the U.S., refer to the National Fuel Gas Code ANSI Z223.1 / NFPA 54 (latest edition), and if in Canada, refer to the Natural Gas and Propane Installation Code CSA B149.1 (latest edition).

6.1 Venting Installation Sequence

The venting system shall be installed in accordance with the water heater manufacturer's instructions and, if applicable, the venting system manufacturer's instructions.

1. Install the water heater.
2. Determine the termination method—horizontal, vertical, etc.
3. Determine the proper location for wall or roof penetration for each termination.

NOTE Do not exceed the maximum allowed vent lengths indicated in this manual.

4. Install assembled terminations as described in this manual or according to the vent manufacturer's installation instructions. If necessary, install a bird screen (not supplied with the water heater).
5. Install combustion air and exhaust vent piping from the water heater to the termination.
6. Slope the horizontal vent 1/4 in. upwards every 12 in. (305 mm) toward the termination.
7. Install supports and hanger straps allowing for movement due to expansion, or according to the vent pipe manufacturer's instructions or local code requirements.

6.2 General Requirements

6.2.1 Vent Piping Material

- This is a Category IV appliance. Only vent materials approved for use with Category IV appliances may be used.
 - Under normal conditions, this water heater will not produce an exhaust flue temperature greater than 149°F (65°C) and schedule 40 PVC pipe may be used as the vent material. If the water heater set temperature is 160°F (70°C) or higher and there is a return line to the water heater from either a recirculation pump or a combination space heating system, schedule 40/80 CPVC, polypropylene or stainless steel must be used.
 - This water heater must be vented with plastic pipe or stainless steel pipe materials as specified in the table below.
- Vent installations in Canada that utilize plastic or stainless steel vent systems must comply with ULC S636.

Exhaust vent / Air intake

Material	United States		Canada	
	Exhaust	Air Intake	Exhaust	Air Intake
Schedule 40 PVC	ANSI/ASTM D1785		ULC S636	CSA B137.3
PVC-DWV	ANSI/ASTM D2665		Certified Materials	CSA B181.2
Schedule 40 CPVC	ANSI/ASTM F441		Only	CSA B137.3
Polypropylene*	Centrotherm- InnoFlue® (certified ULC S636 and UL 1738), DuraVent PolyPro® (certified ULC S636)			
System 1738™ PVC Fuel Gas Venting	IPEX Management Inc. (certified UL 1738)			
Stainless Steel*	DuraVent- FasNSeal® (certified UL1738 and ULC S636)			

- * Only the manufacturer specified vent parts listed below may be used for this water heater. Refer to the manufacturer's literature for detailed information.
- Approved vent manufacturer:
 - Centrotherm- InnoFlue® polypropylene

	Parts #
Single Wall Pipe (2 in. / 3 in.)	ISVL02xx(UV)/03xx(UV), ISEP02xx/03xx, ISIA0203
Elbow	ISELLO287(UV)/0387(UV), ISELS0245/0345
Termination**	ISELLO287UV/0387UV, ISTT0220/0320, ICWT242/352***, ICTCR24, ICCT3503, ICTC0335***
Bird Screen	IASPP02/03

- DuraVent PolyPro® / FasNSeal®

	Parts #
Single Wall Pipe (2 in. / 3 in.)	2PPS-xxBL/3PPS-xxBL, 2PPS-xxL/3PPS-xxL, FSVLxx03, FSAVL3(-2)
Elbow	2PPS-E90(B)L/3PPS-E90(B)L, 2PPS-E45(B)L/3PPS-E45(B)L, FSELB9003/8803/4503/1503
Termination**	2PPS-E90(B)L/3PPS-E90(B)L, 2PPS-T(B)L/3PPS-T(B)L, 2PPS-HKC/3PPS-HKC***, FSTT3, FSTB3, FSRC3
Bird Screen	2PPS-BG/3PPS-BG, FSBS3
FasNSeal Adapter	FSA-2PVCS-3FNFS

- ** Only the terminals listed above are applicable for the water heater.
- *** These terminations are polypropylene concentric vent terminations. PVC to polypropylene adapters are included in the box for each vent manufacturer. These adapters shall not be used for connecting the appliance to concentric vent termination. The appliance's flue collars (flue connections) are designed to fit 2 in. diameter polypropylene vent piping.

Pipe cement/primer

Material	United States	Canada
PVC	ANSI/ASTM D2564	ULC S636 Certified Materials Only
CPVC	ANSI/ASTM F493	

⚠ WARNING

Use of cellular core PVC (ASTM F891), cellular core CPVC, or Radel® (polyphenylsulfone) in non-metallic venting systems is prohibited for the exhaust vent.

- Use only a solid PVC / CPVC (schedule 40), polypropylene or stainless steel pipe.
- A 2 in., 3 in. or 4 in. schedule 80 pipe may also be used on this water heater; however, the Btu/h input of the water heater will be reduced by up to 15%.
- Maintain the same vent pipe diameter from the water heater flue to the termination.
- In Canada, plastic vent systems must be certified under ULC S636. The components of the certified vent system must not be combined with other vent systems or unlisted pipe/fittings.
- In Canada, specified primers and glues used with ULC S636 certified vent systems must be from a single system manufacturer and not combined with other system manufacturers' vent system parts.

NOTE Covering non-metallic vent pipes and fittings with thermal insulation is prohibited.

6.2.2 Installation Instructions

⚠ WARNING

CARBON MONOXIDE POISONING

Failure to properly seal the vent system could cause flue products to enter the living space.

- Follow all general venting guidelines as outlined in this manual.
- Clearance described in this document is the minimum recommended/required distance. Allow appropriate clearance according to the situations of the site.
- Make sure the vent system is gas tight and will not leak.
- Support the vent pipe with hangers at regular intervals as specified by these instructions or the instructions of the vent manufacturer.
- All piping must be fully supported. Use pipe hangers at a minimum of 3 ft (0.9 m) intervals.

NOTE Do not use the water heater to support the vent piping.

- When installing intake and exhaust terminations near the corner of the inside wall, install the exhaust termination closer to the inside wall. Ensure a distance of at least 1 ft (0.3 m) between the inside wall and the exhaust termination.
- Clearance to opposite wall is at a minimum of 24 in. (60 cm).

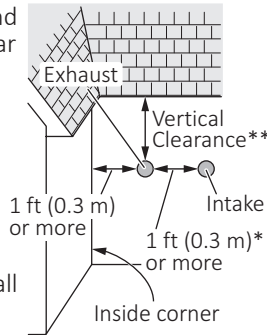

* The clearance between intake and exhaust terminations must be provided in accordance with page 23 for horizontal vent termination.

** Clearance requirement is in accordance with page 21. This vertical clearance must be considered to prevent exhaust accumulation under the soffit.

- When preparing and assembling the pipe, follow instructions as provided by the pipe manufacturer. In general, the following practices must be observed:
 - Squarely cut all pieces of pipe.
 - Remove all burrs and debris from joints and fittings.
 - All joints must be properly cleaned, primed, and cemented. Use only cement and primer approved for use with the pipe material as outlined on page 17.
- PVC, CPVC or polypropylene pipe has been approved for use on this water heater with zero clearance between the pipe and combustibles.
- The pipe must be installed so that the first 3 ft (0.9 m) of pipe from the flue outlet of the water heater is readily accessible for visual inspection.

How to tighten the vent pipe

1. Insert the vent pipe until it reaches the base of the exhaust and intake flue of the water heater.
 - The vent pipe will be inserted approximately 2.3 in. (60 mm).
2. Secure the vent pipe by tightening the band using a screwdriver.
 - The following tightening torque is required:
 - For PVC/CPVC pipe: between 16 and 20 in-lb
 - For polypropylene / stainless steel pipe: between 12 and 15 in-lb

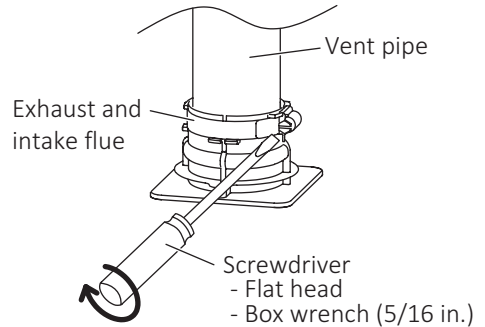

NOTE Do not use electric screwdrivers, impact drivers and the like.

6.2.3 Safety Instructions for the Termination

- Do not store hazardous or flammable substances near the vent termination, and make sure check that the termination is not blocked in any way.
- Steam or condensate may come out of the vent termination. Select a location for the termination that will not cause injury or property damage.
- If heavy snowfall is expected to accumulate, make sure the termination will not be covered with snow or hit by falling lumps of snow.
- The vent for this appliance shall not terminate:
 - i) over public walkways; or
 - ii) near soffit vents or crawl space vents or other areas where condensate or vapor could create a nuisance or hazard or cause property damage; or
 - iii) where condensate vapor could cause damage or could be detrimental to the operation of regulators, relief valves, or other equipment.
- A bird screen must be installed on the terminations to prevent debris or animals from entering the piping. These screens are not supplied with the water heater and must be purchased separately.

	Vent Material	Bird Screen Parts #
PVC or CPVC	2 in. (50 mm)	VT2-PVCS
	3 in. (75 mm)	VT3-PVCS
	4 in. (100 mm)	VT4-PVCS

Vent Material		Bird Screen Parts #
Polypropylene	Centrotherm- 2 in. (50 mm)	IASPP02
	Centrotherm- 3 in. (75 mm)	IASPP03
	DuraVent- 2 in. (60 mm)	2PPS-BG
Stainless Steel	DuraVent- 3 in. (80 mm)	3PPS-BG
	DuraVent- 3 in. (75 mm)	FSBS3

- The following IPEX termination can also be used.

Item	Item #
Universal Concentric Vent Kit (UCVK)* (PVC ULC S636/UL 1738- Certified for use in both Canada and USA)	PVC-UCVK (397007)
IPEX Low Profile Termination Kit** (PVC ULC S636/UL 1738- Certified for use in both Canada and USA)	2 in. PVC-2LPT (397100)
	3 in. PVC-3LPT (397101)

NOTE Below are additional models approved for use by Noritz and supplied by IPEX. Refer to the IPEX literature or website for additional details.

- * Universal concentric vent kit :

<USA>	#397256- PVC System 1738
<Canada>	#196256- PVC System 636
	#197256- CPVC System 636

- ** Low profile termination kit :

<USA>	#397984- 2" PVC System 1738
	#397985- 3" PVC System 1738
<Canada>	#196984- 2" PVC System 636
	#196985- 3" PVC System 636

6.2.4 Vent Length

- This water heater has been designed to be vented with 2 in. (50 mm), 3 in. (75 mm) or 4 in. (100 mm) PVC, CPVC or polypropylene; 3 in. (75 mm) stainless steel.
- The minimum total vent length including horizontal and vertical vent runs should not be less than 3 ft (0.9 m).
- The water heater can be adjusted to accommodate longer vent runs. Refer to the table below. Do not exceed the maximum vent length.
- When installation is complete, change the settings according to the vent length. For how to configure the settings, see page 47 when using the operation panel, or see page 50 when using the app.

The settings vary according to the vent material. See the information on the applicable material listed below and fill in the information needed for the settings.

Vent Type: _____

Vent Size (DV or SV type only): _____

Vent Length: _____

Short or Long: _____

For PVC / CPVC / polypropylene / stainless steel material

- The maximum vent length when using 2 in. (50 mm) pipe is 75 ft (23 m).
- The maximum vent length when using 3 in. (75 mm) pipe is 150 ft (46 m).
- The maximum vent length when using 4 in. (100 mm) pipe is 65 ft (20 m).

Both maximum lengths are reduced by the number of elbows used, as shown in the following table:

Vent diameter	Maximum equivalent vent length* ¹ V (Vertical) + H (Horizontal)	Maximum number of elbows* ²	Equivalent length of components
2 in. (50 mm)	75 ft (23 m)	7	90° elbow: 5 ft (1.5 m)
3 in. (75 mm)	150 ft (46 m)	15	45° elbow: 3 ft (0.9 m)
4 in. (100 mm)	65 ft (20 m)	6	

*1 The maximum vent length includes elbows.

*2 Not including the termination.

Vent length calculation example

Step 1:

Vent diameter
2 in.

Step 2:

Straight pipe length
(Vertical length + horizontal length)
17 ft

Step 3:

Number of elbows
90° elbows: 2
45° elbows: 2

Step 4:

Calculate equivalent length
90° elbows: 2 × 5 ft = 10 ft
45° elbows: 2 × 3 ft = 6 ft

Step 5:

Total vent length
(Add step 2 and step 4 together)
17 ft + 16 ft = 33 ft

Vent length configurations

Vent diameter	Vent length	Short or Long
2 in. (50 mm)	Less than 33 ft	Short
	33 ft or more	Long
3 in. (75 mm) or 4 in. (100 mm)	Less than 75 ft	Short
	75 ft or more	Long

6.3 Selecting a Vent Type

Operation panel settings

Vent Type	Vent Size	Vent Length
Direct Vent (DV)	2 inch/3 inch (4 inch)	Short/Long
Single Vent (SV)	2 inch/3 inch (4 inch)	Short/Long
Outdoor (OD)	2 inch* (Initial setting)	Short* (Initial setting)
Flex Single Vent 2"	Not applicable. Do not select.	
Flex 3" Through Chimney	Not applicable. Do not select.	
Common Direct Vent	2 inch* (Initial setting)	Short* (Initial setting)
Common Single Vent	2 inch* (Initial setting)	Short* (Initial setting)

* Be sure to select this setting; otherwise, the water heater will stop with error code 73 or 731. For other vent types, select the setting according to the size and length.

Direct Vent

- Set the vent type setting to "Direct Vent (DV)".
- Combustion air is supplied from outdoors. Combustion air and exhaust gas use separate vent pipes.

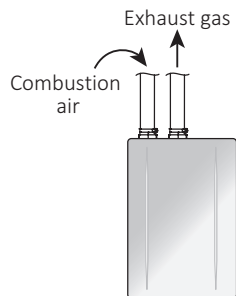

Non-Direct Vent

With SV conversion kit (SV-CK-2-1)

- Set the vent type setting to "Single Vent (SV)".
- Combustion air is supplied from the surrounding indoor air.

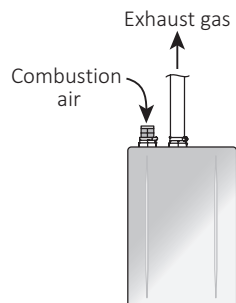

Outdoor

With outdoor vent cap (VC-6-1)

- Set the vent type setting to "Outdoor (OD)".
- The water heater can be installed outside using the outdoor vent cap.

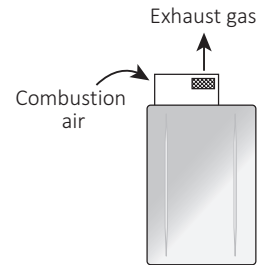

Common Vent

This water heater is suitable for a common vent system. To make a common vent system, contact Noritz America at 1-866-766-7489 or scan the following two-dimensional barcode and then refer to the common vent installation manual for detailed information.



Common Direct Vent

Set the vent type setting to "Common Direct Vent".

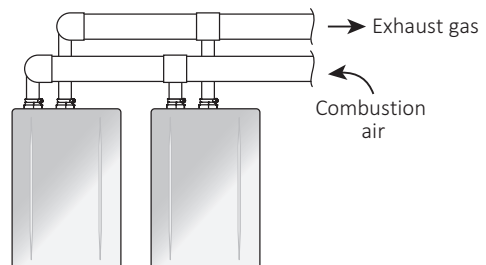

⚠ WARNING

Exhaust gas and combustion air must not be combined in a single PVC pipe using a "Y" fitting.

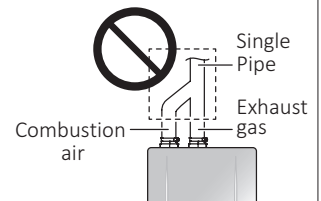

Common Single Vent

Set the vent type setting to "Common Single Vent".

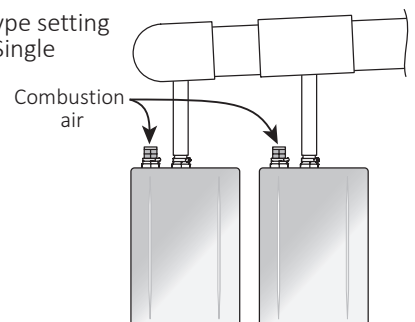

6.4 Vent Pipe Installation (Direct Vent)

6.4.1 Clearance Requirements from Vent Terminations to Building Openings (When supplying combustion air from the outdoors)

All clearance requirements are in accordance with ANSI Z21.10.3 and the National Fuel Gas Code, ANSI Z223.1 and in Canada, in accordance with the Natural Gas and Propane Installation Code CSA B149.1.

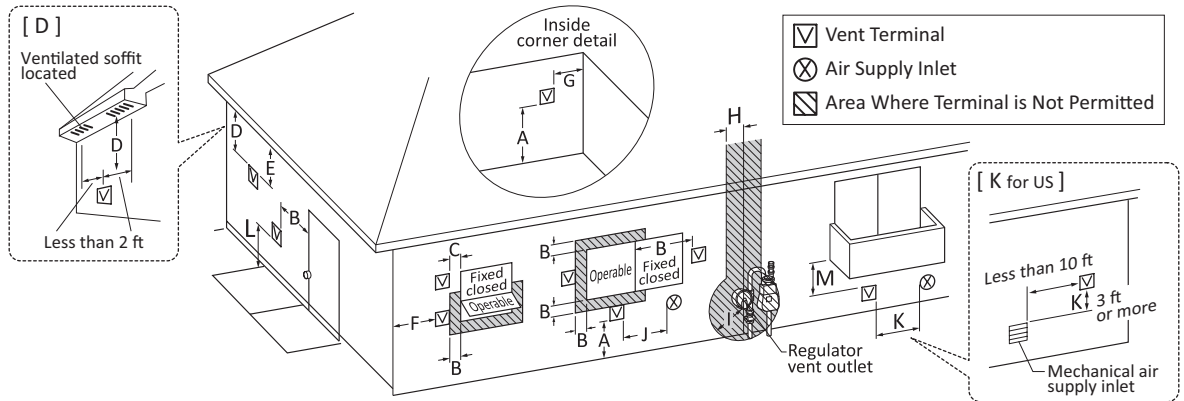

Ref	Description	Canadian Direct Vent Installations ¹	US Direct Vent Installations ²
A	Clearance above grade, veranda, porch, deck, or balcony	12 in. (30 cm)	12 in. (30 cm)
B	Clearance to window or door that may be opened	36 in. (91 cm)	12 in. (30 cm)
C	Clearance to permanently closed window	N/A	N/A
D	Vertical clearance to ventilated soffit located above the terminal within a horizontal distance of 2 feet (61 cm) from the center line of the terminal	2 ft (61 cm)	2 ft (61 cm)
E	Clearance to unventilated soffit	12 in. (30 cm)	12 in. (30 cm)
F	Clearance to outside corner	N/A	N/A
G	Clearance to inside corner	12 in. (30 cm)	12 in. (30 cm)
H	Clearance to each side of center line extended above meter/regulator assembly	3 ft (91 cm) up to a height of 15 ft (4.5 m) above the regulator vent outlet	3 ft (91 cm) up to a height of 15 ft (4.5 m) above the regulator vent outlet
I	Clearance to service regulator vent outlet	Above a regulator within 3 ft (91 cm) horizontally of the vertical center line of the regulator vent outlet to a maximum vertical distance of 15 ft (4.5 m)	3 ft (91 cm) for gas pressures up to 2 psi; 10 ft (3 m) for gas pressures above 2 psi
J	Clearance to non-mechanical air supply inlet to building or the combustion air inlet to any other appliance	36 in. (91 cm)	12 in. (30 cm)
K	Clearance to a mechanical air supply inlet	6 ft (1.83 m)	3 ft (91 cm) above if within 10 ft (3 m) horizontally
L	Clearance above paved sidewalk or paved driveway located on public property	7 ft (2.13 m)†	7 ft (2.13 m) and shall not be located above public walkways or other areas where condensate or vapor can cause a nuisance or hazard.
M	Clearance under veranda, porch, deck, or balcony	12 in. (30 cm)‡	12 in. (30 cm) where the area beneath the veranda, porch, deck or balcony is open on not less than two sides. The vent terminal is prohibited in this location where only one side is open.

* If locally adopted installation codes specify clearances different than those illustrated, then the most stringent clearance shall prevail.

¹ In accordance with the current CSA B149.1 Natural Gas and Propane Installation Code

² In accordance with the current ANSI Z223.1 / NFPA 54 National Fuel Gas Code

† A vent shall not terminate directly above a sidewalk or paved driveway that is located between two single family dwellings and serves both dwellings.

‡ Permitted only if veranda, porch, deck, or balcony is fully open on a minimum of two sides beneath the floor.

6.4.2 Horizontal Vent Termination

For horizontal vent termination - PVC, CPVC, polypropylene or stainless steel material

- Use a condensation drain if necessary.
- In the Commonwealth of Massachusetts, a carbon monoxide detector is required for all side wall horizontally vented gas fuel equipment. Refer to the page 4 for more detailed information.

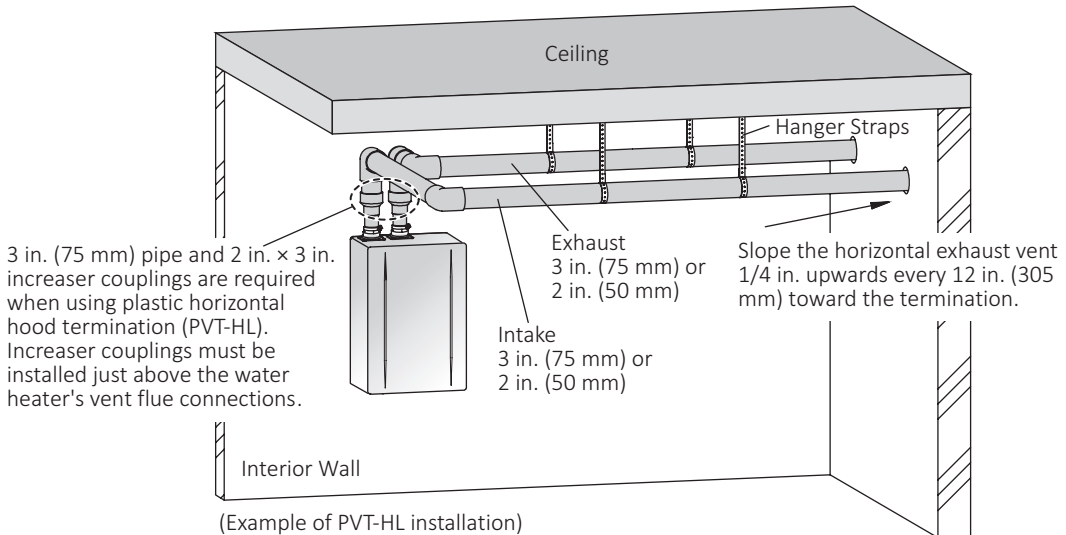

(Example of PVT-HL installation)

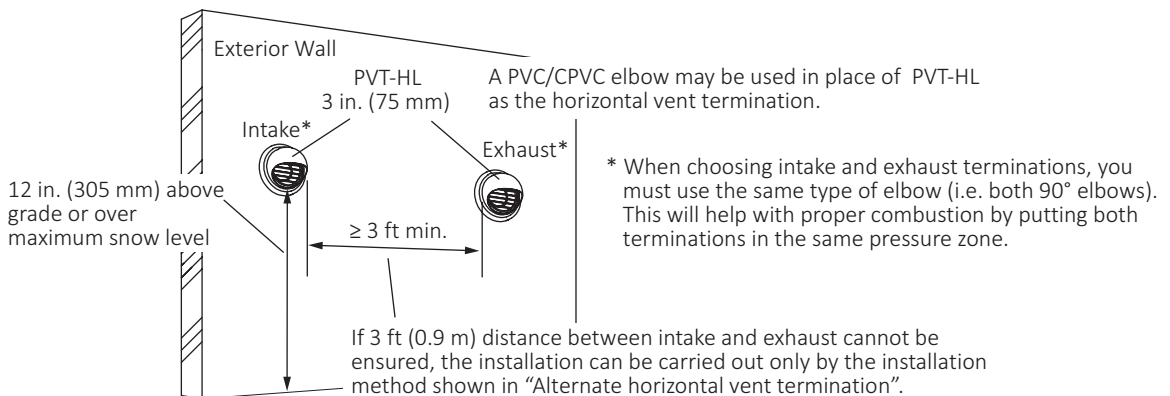

(Example of PVC-2LPT installation)

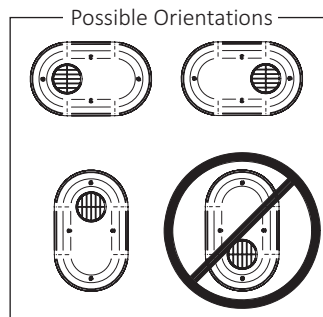
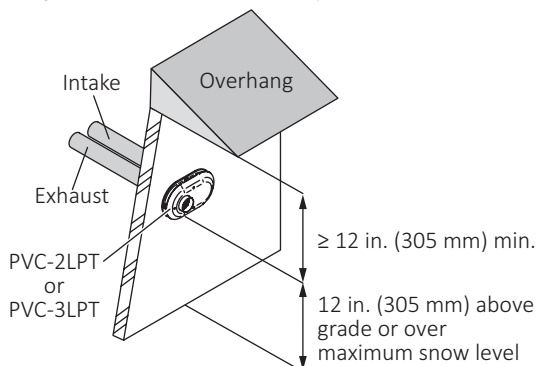

Alternate horizontal vent termination - PVC, CPVC, polypropylene or stainless steel material

(When 3 ft (0.9 m) distance between intake and exhaust cannot be ensured.)

⚠ WARNING

- If the distance between the air intake and exhaust vent terminations is too short, the water heater will draw in the exhaust gases through the intake. That poses a risk of inadequate combustion air for the water heater, thus increasing carbon monoxide (CO) emissions and noise due to vibration.
- Termination elbows must be oriented vertically, pointing directly downward. Attempts to prevent exhaust air from entering the air inlet by angling termination elbows in directions other than directly downward will increase the risk of freezing.
- Reversing the air intake and exhaust pipes is not allowed. Carbon monoxide (CO) emissions and noise due to vibration will increase if they are reversed.

- Insert the bird screen into the 90° elbow installed vertically downward.
- Intake and exhaust should face the same direction. Intake and exhaust should be in the same pressure zone.

NOTE Do not use hood termination (PVT-HL).

Interior View

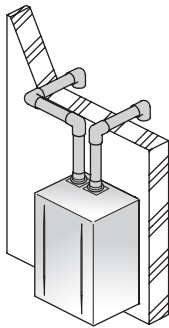

Exterior View

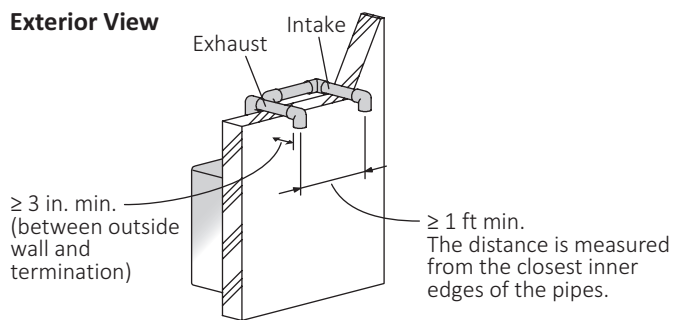

Interior View

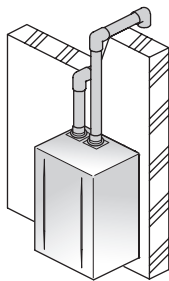

Exterior View

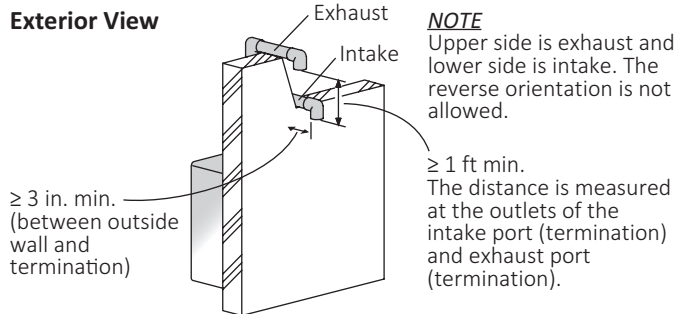

Interior View

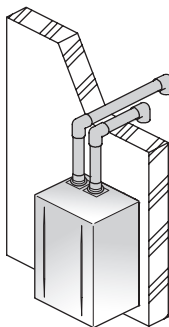

Exterior View

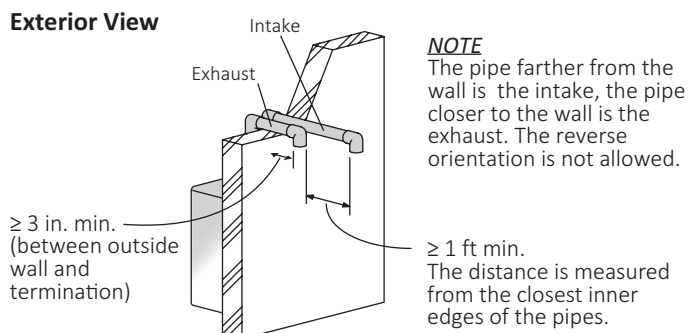

For horizontal PVC concentric termination - PVC/CPVC/polypropylene material only

- The concentric termination may be shortened, but not lengthened from the length when supplied from the factory.
- 2 in. (50 mm) or 3 in. (75 mm) PVC, CPVC or polypropylene pipe may be used with the concentric termination. Maintain the same vent pipe diameter from the water heater flue to the termination.
- Use a condensation drain if necessary.
- In the Commonwealth of Massachusetts, a carbon monoxide detector is required for all side wall horizontally vented gas fuel equipment. Refer to the page 4 for more detailed information.

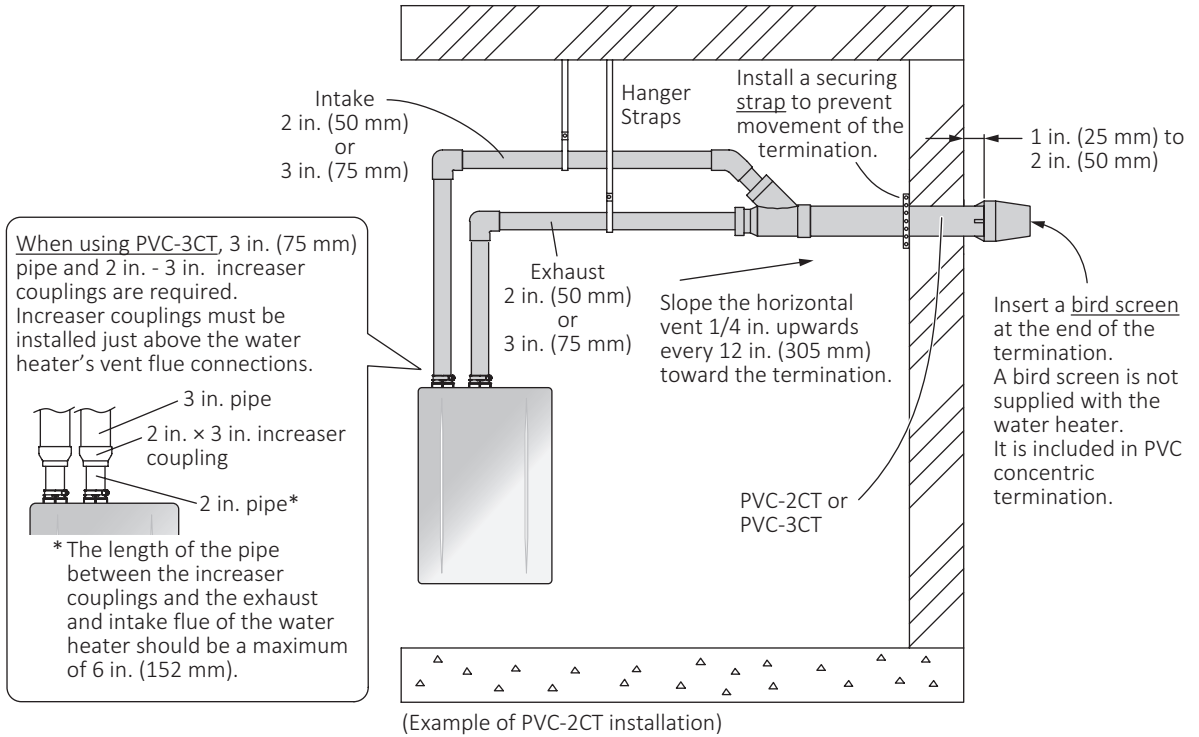

For universal concentric vent kit

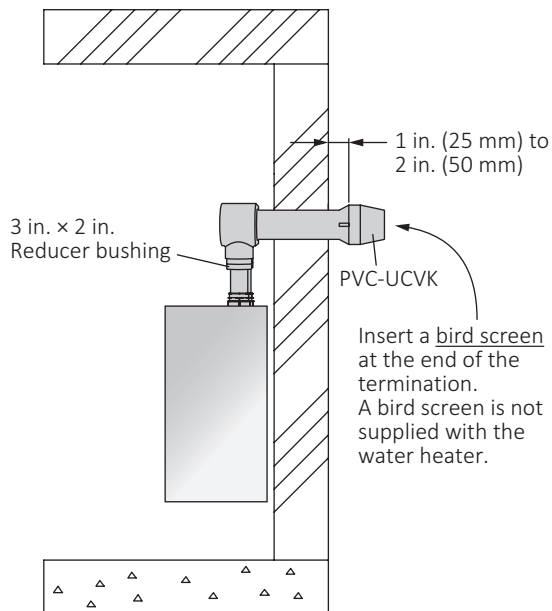

6.4.3 Vertical Vent Termination

For vertical vent termination - PVC, CPVC, polypropylene or stainless steel material

*About the termination

- Intake and exhaust terminations must use the same type of elbow (i.e. both 90° elbows). This will help with proper combustion by putting both terminations in the same pressure zone.
- Insert a bird screen at the end of 90° elbow.
- A bird screen is not supplied with the water heater. Order it separately.
- To prevent excessive condensation formation, only the vent termination should be located outside of the building.

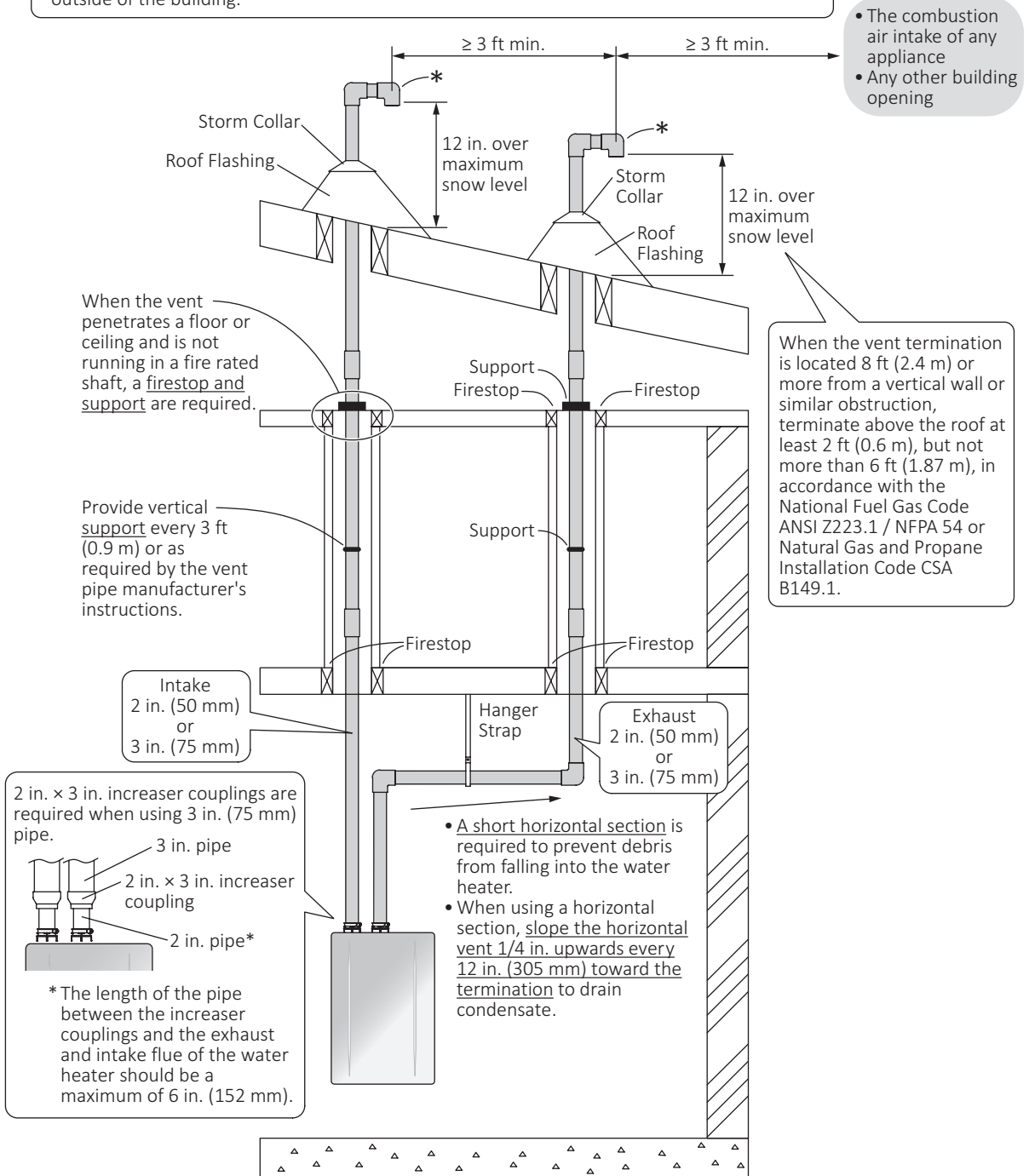

For vertical PVC concentric termination - PVC/CPVC/polypropylene material only

- The concentric termination may be shortened, but not lengthened from the length when supplied from the factory.
- 2 in. (50 mm) or 3 in. (75 mm) PVC, CPVC or polypropylene pipe may be used with the concentric termination. Maintain the same vent pipe diameter from the water heater flue to the termination.
- Use a condensation drain if necessary.
- In the Commonwealth of Massachusetts, a carbon monoxide detector is required for all side wall horizontally vented gas fuel equipment. Refer to the page 4 for more detailed information.

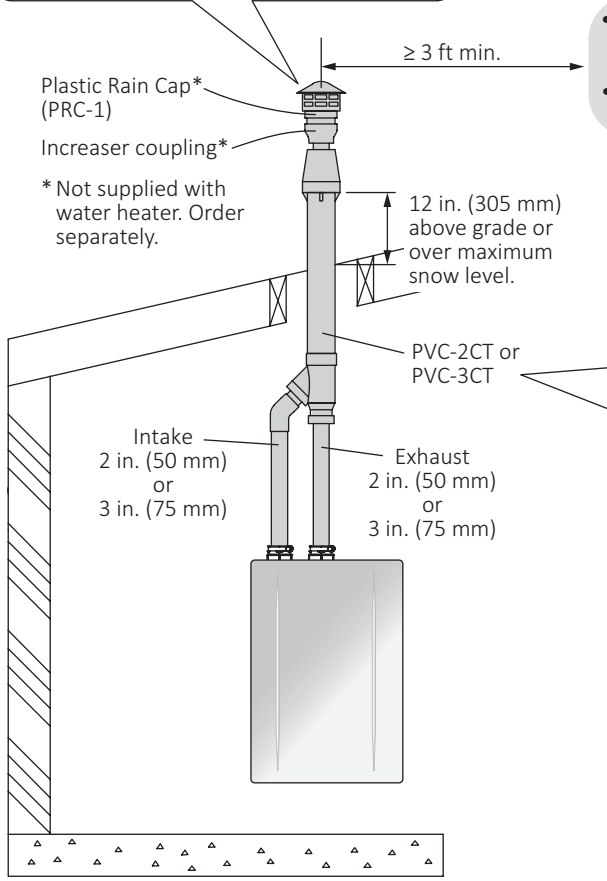
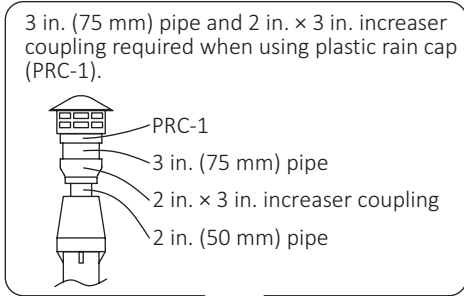

- The combustion air intake of any appliance
- Any other building opening

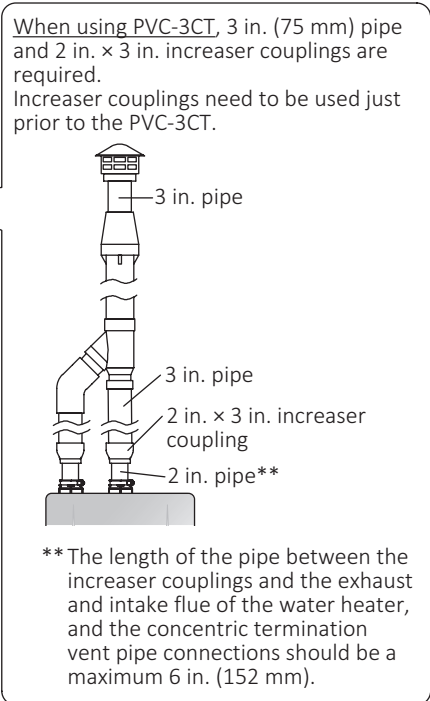

(Example of PVC-2CT installation)

6.5 Vent Pipe Installation (Non-Direct Vent)

6.5.1 Clearance Requirements from Vent Terminations to Building Openings (Other than Direct Vent)

All clearance requirements are in accordance with ANSI Z21.10.3 and the National Fuel Gas Code, ANSI Z223.1 and in Canada, in accordance with the Natural Gas and Propane Installation Code CSA B149.1.

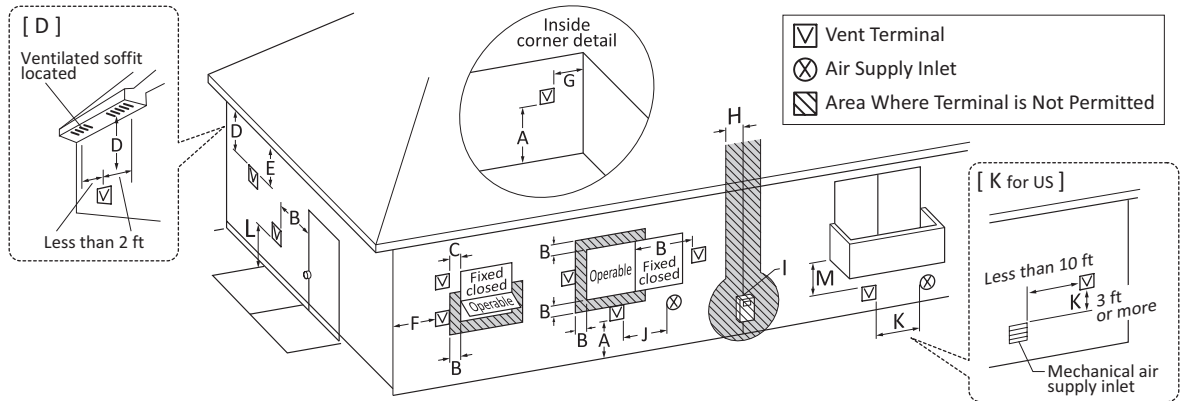

Ref	Description	Canadian Non-Direct Vent Installations ¹	US Non-Direct Vent Installations ²
A	Clearance above grade, veranda, porch, deck, or balcony	12 in. (30 cm)	12 in. (30 cm)
B	Clearance to window or door that may be opened	36 in. (91 cm)	4 ft (1.2 m) below or to side of opening; 1 ft (300 mm) above opening
C	Clearance to permanently closed window	N/A	N/A
D	Vertical clearance to ventilated soffit located above the terminal within a horizontal distance of 2 feet (61 cm) from the center line of the terminal	2 ft (61 cm)	2 ft (61 cm)
E	Clearance to unventilated soffit	12 in. (30 cm)	12 in. (30 cm)
F	Clearance to outside corner	N/A	N/A
G	Clearance to inside corner	12 in. (30 cm)	12 in. (30 cm)
H	Clearance to each side of center line extended above meter/regulator assembly	3 ft (91 cm) up to a height of 15 ft (4.5 m) above the regulator vent outlet	3 ft (91 cm) up to a height of 15 ft (4.5 m) above the regulator vent outlet
I	Clearance to service regulator vent outlet	Above a regulator within 3 ft (91 cm) horizontally of the vertical center line of the regulator vent outlet to a maximum vertical distance of 15 ft (4.5 m)	3 ft (91 cm) for gas pressures up to 2 psi; 10 ft (3 m) for gas pressures above 2 psi
J	Clearance to non-mechanical air supply inlet to building or the combustion air inlet to any other appliance	36 in. (91 cm)	4 ft (1.2 m) below or to side of opening; 1 ft (300 mm) above opening
K	Clearance to a mechanical air supply inlet	6 ft (1.83 m)	3 ft (91 cm) above if within 10 ft (3 m) horizontally
L	Clearance above paved sidewalk or paved driveway located on public property	7 ft (2.13 m)†	7 ft (2.13 m) and shall not be located above public walkways or other areas where condensate or vapor can cause a nuisance or hazard.
M	Clearance under veranda, porch, deck, or balcony	12 in. (30 cm)‡	12 in. (30 cm) where the area beneath the veranda, porch, deck or balcony is open on not less than two sides. The vent terminal is prohibited in this location where only one side is open.

* If locally adopted installation codes specify clearances different than those illustrated, then the most stringent clearance shall prevail.

¹ In accordance with the current CSA B149.1 Natural Gas and Propane Installation Code

² In accordance with the current ANSI Z223.1 / NFPA 54 National Fuel Gas Code

† A vent shall not terminate directly above a sidewalk or paved driveway that is located between two single family dwellings and serves both dwellings.

‡ Permitted only if veranda, porch, deck, or balcony is fully open on a minimum of two sides beneath the floor.

6.5.2 Cautions at Installation

⚠ DANGER

- When installing this water heater in an area with a large amount of lint, such as a commercial laundromat, a direct vent (“DV”) system must be used. The “SV” configuration (using SV conversion kit (SV-CK-2-1)) must not be used.
- When installing this water heater in a mobile home, all combustion air must be drawn directly from the outdoors. The “SV” configuration (using SV conversion kit (SV-CK-2-1)) must not be used.

⚠ WARNING

Failure to change vent type setting by the operation panel or app and use SV conversion kit (SV-CK-2-1) can result in a fire or explosion causing property damage, personal injury, or loss of life. Refer to the installation guide included in the conversion kit for additional details.

- Set the vent type setting to “Single Vent (SV)”. For how to configure the settings, see page 47 when using the operation panel, or see page 50 when using the app.
- SV conversion kit (SV-CK-2-1) is required for the air intake.
- Noritz recommends a carbon monoxide alarm be installed in same room as the water heater when supplying combustion air from indoors.

⚠ WARNING

To prevent possible personal injury or loss of life due to asphyxiation, common venting with other manufacturers’ induced draft appliances is not permitted.

6.5.3 Combustion Air

NOTE Provide adequate combustion air so as not to create negative pressure within the building.

- Supply combustion air to the water heater as per the National Fuel Gas Code, ANSI Z223.1 (latest edition), and in Canada in accordance with the Natural Gas and Propane Installation Code CSA B149.1 (latest edition).

- Minimum free area of each opening:

Indoor make up air is provided		200 in. ²
Example (W) × (H)		20 in. × 10 in.
Outdoor make up air is provided	Direct or Vertical ducts	50 in. ²
	Example (W) × (H)	10 in. × 5 in.
	Horizontal ducts	100 in. ²
Example (W) × (H)		20 in. × 5 in.

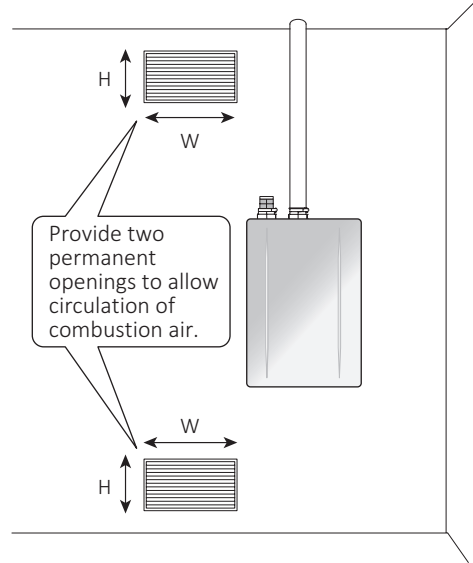

- If the water heater is installed in a mechanical closet, a minimum permanent clearance of 4 in. in front of the water heater is required. In order to facilitate maintenance and repair, a minimum clearance (24 in. or more) should be provided.
- If combustion air will be provided through a duct, size the duct to provide 70 cubic feet of fresh air per minute per unit.

6.5.4 Horizontal Vent Termination

- Use a condensation drain if necessary.
- In the Commonwealth of Massachusetts, a carbon monoxide detector is required for all side wall horizontally vented gas fuel equipment. Refer to the page 4 for more detailed information.

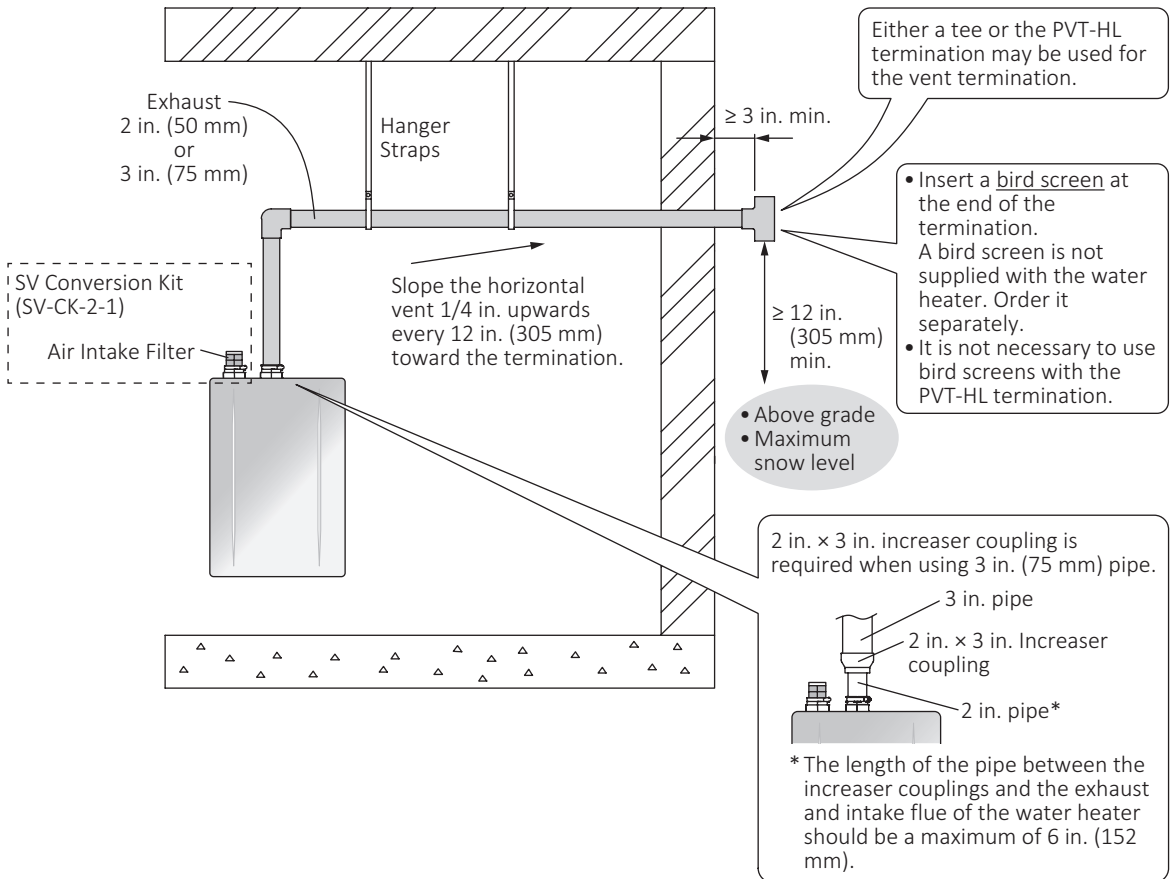

6.5.5 Vertical Vent Termination

*About the termination

- Insert a bird screen at the end of 90° elbow.
- A bird screen is not supplied with the water heater. Order it separately.
- To prevent excessive condensation formation, only the vent termination should be located on the exterior of the building.

- The combustion air intake of any appliance
- Any other building opening

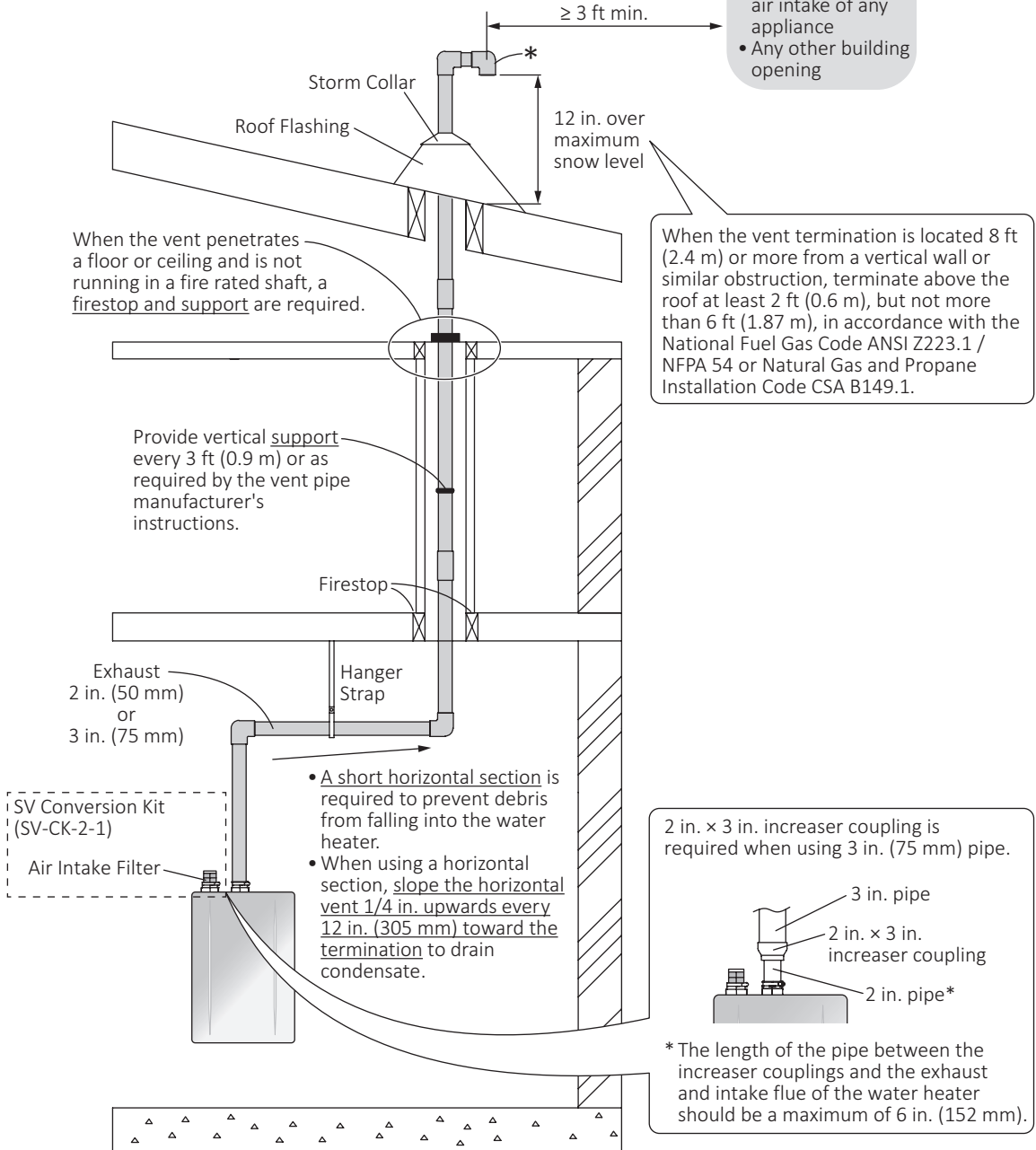

6.6 Outdoor Installation

- When installing this water heater outdoors, the outdoor vent cap (VC-6-1) must be used.
- Refer to the instructions provided with the outdoor vent cap for additional detail.

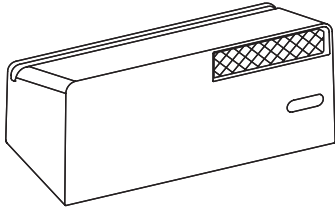

- Set the vent type setting to “Outdoor (OD)”. For how to configure the settings, see page 47 when using the operation panel, or see page 50 when using the app.

7 Connecting the Gas Supply

Follow the instructions from the gas supplier when connecting the gas supply.

⚠ WARNING

The sizing and installation of the gas system for this water heater, as with any gas appliance, is the sole responsibility of the installer. The installer must be professionally trained to do such work, and must always follow all local and national codes and regulations.

Gas Type

THIS WATER HEATER IS EQUIPPED FOR NATURAL GAS.

- This water heater is equipped with orifice for the natural gas.
For conversion to Propane (LP) gas, see the installation guide included in the conversion kit to replace the parts correctly.
Orifice necessary for Propane (LP) conversion is provided with the water heater.
The procedure for conversion can also be accessed from the two-dimensional barcode.
- This conversion kit shall be installed by a qualified installer, service agency, or the gas supplier in accordance with the instructions and all applicable codes and requirements of the authority having jurisdiction. If the information in these instructions is not followed exactly, a fire, an explosion, or production of carbon monoxide can result causing property damage, personal injury, or loss of life. The qualified installer, service agency, or the gas supplier is responsible for the proper installation of this kit. The installation is not proper and complete until the operation of the converted appliance is checked as specified in the instructions supplied with the kit.
- Improper installation of this kit will void the Noritz America Limited Warranty.



Meter

- The gas meter must be a suitable size for the water heater and other gas appliances to operate properly.
- Select a gas meter capable of supplying the entire Btu/h demand of all gas appliances in the building.

Regulators

⚠ WARNING

- Ensure that all gas regulators used are operating properly and providing gas pressures within the specified range of the water heater being installed.
- Excess gas inlet pressure may cause serious accidents.

Pressure

- Check the gas supply pressure when connecting the gas supply immediately at a location provided by the gas company.
- The supplied gas pressure must be within the limits shown in the specifications section with all gas appliances operating.

⚠ WARNING

The inlet gas pressure must be within the range specified. This is for the purposes of input adjustment. Low gas pressure may cause a loss of flame or ignition failure in other appliances in the home, which may result in unburned gas in the home. Serious accidents such as fire or explosion may result.

Pressure Test

The appliance and its gas connections must be leak tested before beginning to operate the appliance.

- Test at a pressure no greater than 1/2 psi (3.5 kPa).
- The appliance must be isolated from the gas supply piping system by closing its individual manual shutoff valve during any pressure testing of the gas supply piping system.
- If test pressures are greater than 1/2 psi (3.5 kPa), the appliance and its individual shutoff valve must be completely disconnected from the gas supply piping system during the test process.

Measuring Gas Pressure

In order to check the gas supply pressure to the water heater, a tap is provided on the gas inlet.

1. Remove the 9/32 in. hex head/ phillips screw from the tap.

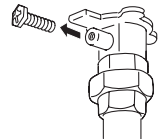

2. Connect a manometer using a silicon tube.
3. Fully open at least two fixtures on the hot water side.

NOTE At the maximum combustion setting, ensure a flow rate of at least 4 GPM. If the flow rate is less than 4 GPM, the temperature of the dispensed hot water can be excessively high.

4. Make sure that the water heater is turned on.
5. Press the up and down buttons at the same time.
 - Setting must be done within the first 10 minutes of connecting the electrical power to the water heater.
6. Use the up or down button to select "Maintenance Menu", then press the OK button.
7. Select "Fixed Combustion", then press the OK button.
8. Select "Max", then press and hold the OK button for about 5 seconds.

Fixed Combustion	1/2
1 .Min	
2 .Max	
Press & hold "OK" for 5s	

- The water heater performs to its maximum heating capacity.
9. After measuring the gas pressure, press the OK button.

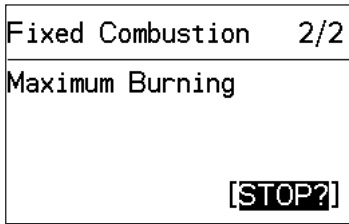

- The unit returns from maximum combustion to normal combustion.

Pipe Sizing

- A gas shutoff valve must be installed on the supply line.
- Gas piping must meet local utility company requirements. In the absence of local codes, use the latest edition of National Fuel Gas Code (NFPA54GC), ANSI Z223.1. In Canada, use the latest edition of CSA B149.1, Natural Gas and Propane Installation Code.
- Size the gas line according to the total Btu/h demand of the building and length from the meter or regulator so that the following supply pressures are available even at maximum demand.

	Supply Pressure	
	Natural Gas	Propane (LP) Gas
Min	3.5 in. W.C.	8 in. W.C.
Max	10.5 in. W.C.	13 in. W.C.

⚠ WARNING

Gas pressures below the required minimum pressure may result in ignition failure, personal injury, or loss of life.

Flexible Connectors

Flexible gas lines are not recommended unless the minimum inside diameter is 3/4 in. or greater and the rated capacity of the connector is equal to or greater than the Btu/h demand of the water heater.

Reference Tools and Sample Calculations

NOTICE

The tables and samples below are for reference only. The professional sizing and installing the gas line should always run the appropriate calculations before all installations.

Calculation Example

A partial set of sizing tables is printed on page 35. In cases where these tables are not appropriate, refer to information provided by the NFPA.

1. Draw a sketch of a piping system. Enter the system information.

(Example)

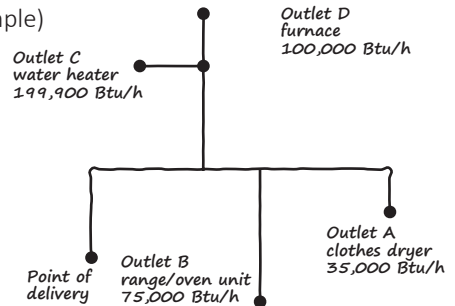

2. • Determine the gas type used and supply gas pressure, and enter them below.
• Determine the piping material and enter it below.
• Select the appropriate pipe sizing table from page 35 and enter it below.

(Example)

Gas type: Natural
Supply gas pressure: 6 in. W.C.
Piping material: Sch 40 steel
Table used: 2
Pressure drop: 1.0 in. W.C.

Gas type: _____
Supply gas pressure: _____
Piping material: _____
Table used: _____
Pressure drop: _____

- In the sketch, label the section of pipe from the point of delivery (meter or regulator) to the first tee as Section 1.
 - Label the section from the first tee to the second tee as Section 2, and label the section from the first tee to the third tee as Section 3. Use similar section numbers for additional sections.

(Example)

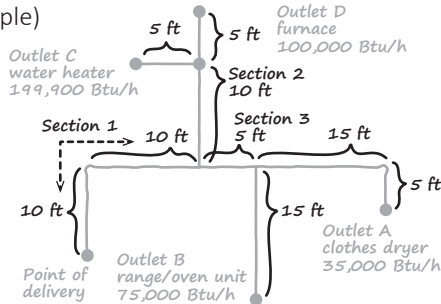

- Enter the demand as the amount of gas flowing through a section of pipe in the table below.
 - For natural gas, use total Btu/h rating/1000 (ft³/h).
 - For propane, use total Btu/h.
 - For each section, determine the longest piping from the point of delivery to the furthest appliance. Enter this length for all pipe sections in the table below.
 - Round up to the lengths to those in the appropriate table on page 35. Find the pipe length in the table, read down from that to a capacity equal to or greater than the required demand for the section, and then read left to find the pipe size. Repeat for each section of piping, entering the sizes in the table below.

(Example)

Section	Demand	Longest length	Size
1	409.9	45 ft	1 in.
2	299.9	35 ft	1 in.
3	110	45 ft	3/4 in.
4			
5			

Section	Demand	Longest length	Size
1			
2			
3			
4			
5			

- Enter the input rating for each appliance in the table below.
 - For natural gas appliances, enter the input rating in Btu/h/1000 (ft³/h).
 - For propane appliances, enter the input rating in Btu/h.
 - Enter the outlet length from each appliance to the point of delivery in the table below.
 - Round up to the lengths to those in the appropriate table on page 35. Find the pipe length in the table, read down from that to a capacity equal to or greater than the required demand for the section, and then read left to find the pipe size. Repeat for each appliance, entering the sizes in the table below.

(Example)

Appliance	Input rating	Outlet length	Size
Outlet A	35	45 ft	1/2 in.
Outlet B	75	40 ft	1/2 in.
Outlet C	199.9	35 ft	3/4 in.
Outlet D	100	35 ft	1/2 in.

Appliance	Input rating	Outlet length	Size
Outlet A			
Outlet B			
Outlet C			
Outlet D			

Final Check

- Turn on and operate all gas appliances including the water heater.
- Make sure the inlet pressure at each appliance is such that the supply pressure at the appliance is greater than or equal to the minimum pressure required by the appliance.

NOTE If all appliances are not receiving the minimum inlet pressure, the gas piping system may need to be changed.

Gas pipe sizing tables

- These tables are for reference only. Consult the gas pipe manufacturer for actual pipe capacities.
- These are examples for schedule 40 metallic pipe.
- (Only table 1- 4) Values in Table are in ft³ of gas per hour. Contact your gas supplier for Btu/ft³ ratings. For simplification of your calculations, 1 ft³ of gas is approximately equivalent to 1,000 Btu/h.

1. Maximum Natural Gas Delivery Capacity (For Less than 6 in. W.C. initial supply pressure)														
0.5 in. W.C. Pressure Drop														
Pipe Size	Length (including fittings)													
	10 ft (3 m)	20 ft (6 m)	30 ft (9 m)	40 ft (12 m)	50 ft (15 m)	60 ft (18 m)	70 ft (21 m)	80 ft (24 m)	90 ft (27 m)	100 ft (30 m)	125 ft (38 m)	150 ft (45 m)	175 ft (53 m)	200 ft (60 m)
1/2 in.	172	118	95	81	72	65	60	56	52	50	44	40	37	34
3/4 in.	360	247	199	170	151	137	126	117	110	104	92	83	77	71
1 in.	678	466	374	320	284	257	237	220	207	195	173	157	144	134
1 1/4 in.	1,390	957	768	657	583	528	486	452	424	400	355	322	296	275
1 1/2 in.	2,090	1,430	1,150	985	873	791	728	677	635	600	532	482	443	412
2 in.	4,020	2,760	2,220	1,900	1,680	1,520	1,400	1,300	1,220	1,160	1,020	928	854	794
2 1/2 in.	6,400	4,400	3,530	3,020	2,680	2,430	2,230	2,080	1,950	1,840	1,630	1,480	1,360	1,270
2. Maximum Natural Gas Delivery Capacity (For 6 - 7 in. W.C. initial supply pressure)														
1.0 in. W.C. Pressure Drop														
Pipe Size	Length (including fittings)													
	10 ft (3 m)	20 ft (6 m)	30 ft (9 m)	40 ft (12 m)	50 ft (15 m)	60 ft (18 m)	70 ft (21 m)	80 ft (24 m)	90 ft (27 m)	100 ft (30 m)	125 ft (38 m)	150 ft (45 m)	175 ft (53 m)	200 ft (60 m)
1/2 in.	250	172	138	118	105	95	87	81	76	72	64	58	53	50
3/4 in.	524	360	289	247	219	199	183	170	160	151	134	121	111	104
1 in.	986	678	544	466	413	374	344	320	300	284	252	228	210	195
1 1/4 in.	2,030	1,390	1,120	957	848	768	707	657	617	583	516	468	430	400
1 1/2 in.	3,030	2,090	1,680	1,430	1,270	1,150	1,060	985	924	873	774	701	645	600
2 in.	5,840	4,020	3,230	2,760	2,450	2,220	2,040	1,900	1,780	1,680	1,490	1,350	1,240	1,160
2 1/2 in.	9,310	6,400	5,140	4,400	3,900	3,530	3,250	3,020	2,840	2,680	2,380	2,150	1,980	1,840
3. Maximum Natural Gas Delivery Capacity (For 7 - 8 in. W.C. initial supply pressure)														
2.0 in. W.C. Pressure Drop														
Pipe Size	Length (including fittings)													
	10 ft (3 m)	20 ft (6 m)	30 ft (9 m)	40 ft (12 m)	50 ft (15 m)	60 ft (18 m)	70 ft (21 m)	80 ft (24 m)	90 ft (27 m)	100 ft (30 m)	125 ft (38 m)	150 ft (45 m)	175 ft (53 m)	200 ft (60 m)
1/2 in.	364	250	201	172	153	138	127	118	111	105	93	84	77	72
3/4 in.	762	524	420	360	319	289	266	247	232	219	194	176	162	151
1 in.	1,440	986	792	678	601	544	501	466	437	413	366	332	305	284
1 1/4 in.	2,950	2,030	1,630	1,390	1,230	1,120	1,030	957	898	848	751	681	626	583
1 1/2 in.	4,420	3,030	2,440	2,090	1,850	1,680	1,540	1,430	1,350	1,270	1,130	1,020	938	873
2 in.	8,500	5,840	4,690	4,020	3,560	3,230	2,970	2,760	2,590	2,450	2,170	1,970	1,810	1,680
2 1/2 in.	13,600	9,310	7,480	6,400	5,670	5,140	4,730	4,400	4,130	3,900	3,460	3,130	2,880	2,680
4. Maximum Natural Gas Delivery Capacity (For 8 - 10.5 in. W.C. initial supply pressure)														
3.0 in. W.C. Pressure Drop														
Pipe Size	Length (including fittings)													
	10 ft (3 m)	20 ft (6 m)	30 ft (9 m)	40 ft (12 m)	50 ft (15 m)	60 ft (18 m)	70 ft (21 m)	80 ft (24 m)	90 ft (27 m)	100 ft (30 m)	125 ft (38 m)	150 ft (45 m)	175 ft (53 m)	200 ft (60 m)
1/2 in.	454	312	250	214	190	172	158	147	138	131	116	105	96	90
3/4 in.	949	652	524	448	397	360	331	308	289	273	242	219	202	188
1 in.	1,790	1,230	986	844	748	678	624	580	544	514	456	413	380	353
1 1/4 in.	3,670	2,520	2,030	1,730	1,540	1,390	1,280	1,190	1,120	1,060	936	848	780	726
1 1/2 in.	5,500	3,780	3,030	2,600	2,300	2,090	1,920	1,790	1,680	1,580	1,400	1,270	1,170	1,090
2 in.	10,600	7,280	5,840	5,000	4,430	4,020	3,700	3,440	3,230	3,050	2,700	2,450	2,250	2,090
2 1/2 in.	16,900	11,600	9,310	7,970	7,070	6,400	5,890	5,480	5,140	4,860	4,300	3,900	3,590	3,340
5. Maximum Undiluted Propane (LP) Delivery Capacity in Thousands of Btu/h														
0.5 in. W.C. Pressure Drop														
Pipe Size	Length (including fittings)													
	10 ft (3 m)	20 ft (6 m)	30 ft (9 m)	40 ft (12 m)	50 ft (15 m)	60 ft (18 m)	80 ft (24 m)	90 ft (27 m)	100 ft (30 m)	125 ft (38 m)	150 ft (45 m)	175 ft (53 m)	200 ft (60 m)	
1/2 in.	291	200	160	137	122	110	101	94	89	84	74	67		
3/4 in.	608	418	336	287	255	231	212	197	185	175	155	140		
1 in.	1,150	787	632	541	480	434	400	372	349	330	292	265		
1 1/4 in.	2,350	1,620	1,300	1,110	985	892	821	763	716	677	600	543		
1 1/2 in.	3,520	2,420	1,940	1,660	1,480	1,340	1,230	1,140	1,070	1,010	899	814		
2 in.	6,790	4,660	3,750	3,210	2,840	2,570	2,370	2,200	2,070	1,950	1,730	1,570		

8 Connecting the Water Supply

- Installation and servicing must be performed by a qualified plumber.
- In the Commonwealth of Massachusetts, this product must be installed by a licensed plumber or gas fitter in accordance with Sections 2.00 and 5.00 of the Massachusetts Plumbing and Fuel Gas Code 248 CMR.
- Observe all applicable codes.
- Components used in domestic piping must meet requirements in NSF/ANSI 61: Drinking Water System Components.

8.1 Installation

8.1.1 Guidelines

Installation location

- If the water heater is installed in a closed water supply system, such as one that has a backflow preventer on the cold water supply line, measures must be taken to control thermal expansion. Contact the water supplier or a local plumbing inspector on how to control this situation.
- If the water heater is installed on a roof to supply water to the levels below, make sure that the water pressure supplied to the water heater does not drop below 29 psi. It may be necessary to install a pump system to ensure that the water pressure is maintained at this level or decrease the flow rate by adjusting the water fixture. Check the pressure before beginning to operate the water heater.
Failure to supply the proper pressure to the water heater may result in noisy operation, shorter lifetime of the water heater, and may cause the water heater to shut down frequently.

Potable water

- Piping and components connected to the water heater must be suitable for use with potable water.
- Toxic chemicals, such as those used for boiler treatment, shall not be introduced into the potable water.
- A water heater used to supply potable water must not be connected to any heating system or components previously used with a nonpotable water heating appliance.

Pressure relief valve

- A pressure relief valve must be installed near the hot water outlet. The valve must be rated in accordance with and comply with either the Standard for Relief Valves and Automatic Shutoff Devices for Hot Water Supply Systems, ANSI Z21.22, or the ANSI/ASME Boiler and Pressure Vessel Code, Section IV (Heating Boilers).
- A pressure relief valve must have an hourly Btu rated temperature steam discharge capacity of 199,900 Btu/h.
Multiple valves may be used.
The pressure relief capacity must not exceed 150 psi.
- Do not install a shutoff valve between a relief valve and the water heater.
The relief valve must be installed so that the steam will be discharged to a suitable place for disposal when the pressure is relieved.
- No reducing coupling or other restriction may be installed in the discharge line.
The discharge line must be installed to allow complete drainage of both the valve and the line.
- If this water heater is installed with a separate storage vessel, the separate vessel must have its own temperature and pressure relief valve.
- The temperature and pressure relief valve must also comply with the Standard for Relief Valves and Automatic Gas Shutoff Devices for Hot Water Supply Systems, ANSI Z21.22 (in the U.S. only).
- A temperature relief valve is not required, but if one is used, do not install the valve with the probe directly in the flow of water.
This may cause unwarranted discharge of the valve.
- If the system requires water for space heating at temperatures higher than required for other uses, a means such as a mixing valve shall be installed to temper the water for those uses in order to reduce the potential scald hazard.

Connecting the water supply

- Flush the pipe with water to clean out metal powder, sand and dirt before connecting it.
- Use a union coupling or flexible pipe when connecting the pipes to reduce the force applied to the piping.

- NOTE**
- Do not use piping with a diameter smaller than the coupling.
 - Avoid using joints keep the piping as simple as possible.
 - Avoid piping in which an air holdup can occur.

Cold water supply

- Be sure to check the water pressure.
- The water supply should have a pressure of 15 to 150 psi* (103.4 to 1034 kPa) to enable comfortable use of the water heater.
* 50 to 80 psi is recommended for maximum performance.

- If the water pressure is low, the water heater cannot perform to its full capability, and may cause issues for the client.
- Low water pressure will cause local boiling inside the water heater, causing abnormal sounds and decreasing the durability of the heat exchanger.
- If the water pressure is too high, use a pressure reducing valve and a water hammer arrester.
- Installing a pressure meter on the inlet is recommended.
- Mount a check valve (near the inlet) when required by local code.
- Mount a shutoff valve (near the inlet).

NOTE Do not use PVC, iron, or any piping that has been treated with chromates, boiler seal or other chemicals.

Hot water supply

- Try to make the piping as short as possible. The longer the piping, the greater the heat loss.
- Use a mixing valve and shower heads with low pressure loss.
- If the water supply pressure is insufficient, the maximum water flow rate may not be available. In this situation, a pump may be necessary to increase the water pressure and water flow.
- Noritz recommends the installation of a wye pattern strainer downstream on the hot water supply to prevent loose scale from accumulating and clogging fixtures.

NOTE Do not use lead, PVC, iron or any piping that has been treated with chromates, boiler seal or other chemicals.

8.1.2 Freeze Prevention

Perform the following insulation measures to prevent freezing.

- Take appropriate heat insulation measures (e.g. wrapping with heat insulation materials or using heat tape, electric heaters, solenoids, or pipe covers) according to the climate of the region to prevent the plumbing outside the water heater from freezing. The freeze prevention heaters will not prevent this plumbing from freezing.
- Make sure that there are no water leaks from the cold and hot water supply lines, then insulate the pipes completely.
- Be sure to also completely insulate the water supply valve and the cold and hot water connections on the water heater.
- Refer to the owner's guide for temporary freeze protection measures.

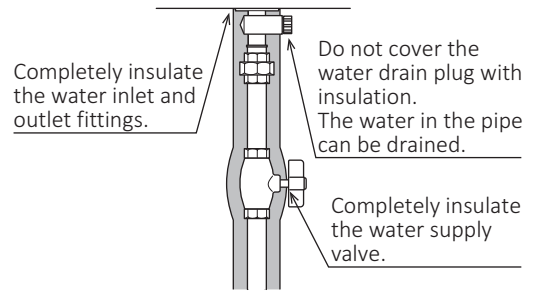

NOTE The water heater must be connected to an electrical power supply at all times to operate the freeze prevention heaters.

Indoor installation

- Freezing is prevented within the water heater automatically unless the outside temperature without wind is below -30°F (-35°C).
- Additional freeze prevention measures are needed if this model is installed in an area where the outside temperature can approach freezing conditions of -30°F (-35°C) or below.

NOTE The room temperature must be greater than 32°F (0°C) to prevent freezing, and the room must not have negative pressure.

Outdoor installation

- Freezing is prevented within the water heater automatically unless the outside temperature without wind is below -4°F (-20°C).
- If this model is installed in an area where the outside temperature can approach freezing conditions of -4°F (-20°C) or below, then additional freeze protection measures must be used.

8.2 Water Treatment

If this water heater will be installed in a location where the hardness of the supply water is high, scale build-up may cause damage to the heat exchanger.

Perform the suggested treatment and maintenance measures based on the water hardness level according to the below table.

Treatment Guidelines

Type of Water	Hardness Level	Treatment Device 1)	Flush Frequency 2)	
			Residential Use	Commercial Use
Soft	0-1 gpg (0-17 mg/L)	None	None	None
Slightly Hard	1-3 gpg (17-51 mg/L)			
Moderately Hard	3-7 gpg (51-120 mg/L)	Scale Shield or Water Softener	Once a Year 3)	Once a Year 3)
Hard	7-10 gpg (120-171 mg/L)			Twice a Year 3)
Very Hard	10-12 gpg (171-200 mg/L)			
Extremely Hard	> 12 gpg (> 200 mg/L)			

- 1) When selecting a treatment device, you must consult its spec sheet and installation manual for guidelines and limitations. Not all water supplies are compatible. A water test may be required.
- 2) Install Noritz isolation valves to allow flushing.
- 3) Flushing is required if a water treatment device is not installed.

NOTE Damage to the water heater as a result of the items below is not covered by the Noritz America Limited Warranty.

- Water in excess of 12 gpg (200 mg/L) of hardness
- Poor water quality (See the water quality list on page 12.)
- The operation panel displayed a “C1# (descaling reminder)” indicating scale build-up, but the heat exchanger has not been flushed.

Water Treatment Device

- The water must be treated with either a Noritz scale shield or a water softener.
- Water softeners may be regulated by the local water jurisdiction. Consult with the manufacturer for code, sizing, and installation guidelines.

The diagram below is for reference only. For more information about scale shields, contact Noritz America at <http://support.noritz.com/> or 1-866-766-7489.

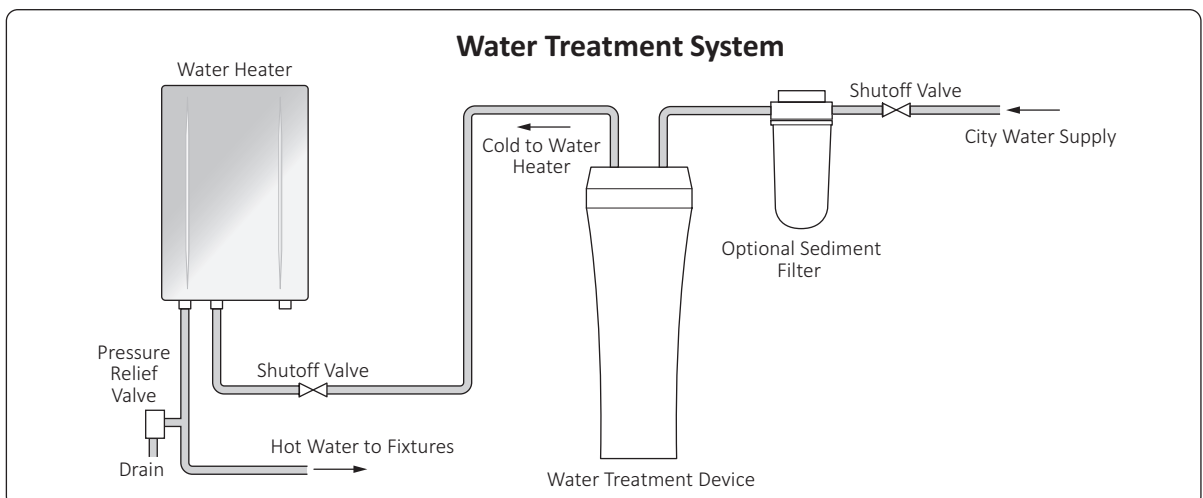

The illustration is for example purposes only. Configure the system according to the actual water heater.

Flushing the Heat Exchanger

The heat exchanger regularly needs to be flushed to prevent damage from scale build-up. Refer to “Procedure for Flushing the Heat Exchanger” on page 70 or contact Noritz America for more information. (<http://support.noritz.com/> or 1-866-766-7489)

About the Descaling Reminder Function

- This water heater is equipped with an automatic descaling reminder function to announce for flushing the heat exchanger.
- If ON is selected for the descaling reminder function, the code “C1#*” will displayed on the operation panel after the set time period has been reached.
When the code is displayed, the heat exchanger needs to be flushed to prevent damage from scale build-up.
* Noritz recommends to flush the heat exchanger when the code “C1#” appears.
= 1, 2, 3, 4 ... 9
- The descaling reminder function is disabled by default.
To use the descaling reminder function, the customer or installer needs to enable it. For how to configure the settings, see page 47 when using the operation panel, or see page 50 when using the app.

When the code “C1#” appears:

Flush the heat exchanger.
Refer to “Procedure for Flushing the Heat Exchanger” on page 70.
After completing the flushing, the code will be reset.

9 Connecting the Condensate Drain

Condensing Water Heater

- In order to ensure proper operation of this water heater, a condensate drain pipe needs to be installed to drain acidic condensate produced during operation.
- The pH level of the condensate is approximately 2-3.
An external neutralizer must be installed on the condensate drain piping prior to disposal when required by local code or when the condensate could cause damage.

NOTE Damage caused by improperly handled condensate is not covered by the Noritz America Limited Warranty.

Location of the Condensate Drain Piping

Do not drain the condensate outdoors in climates where temperatures routinely reach below freezing point.
If the condensate drain pipe freezes during cold weather, the pipe will not drain condensate and the water heater will stop operating.

Material of the Condensate Drain Piping

Use a plastic piping material, such as PVC, for the drain line.

NOTE Do not use steel, black iron, or any other material that can corrode when it comes into contact with acidic condensate.

Sizing of the Condensate Drain Piping

A 1/2 in. threaded fitting is provided at the base of the water heater to drain the condensate.

NOTE Do not reduce the size of the fitting or the condensate drain piping to less than 1/2 in.

If the pipe is long or the nearest drain is above the water heater

A condensate pump needs to be used. Size the pump to allow for a maximum condensate discharge of 2 GPH from the water heater.

Condensate Drain Piping with Pump

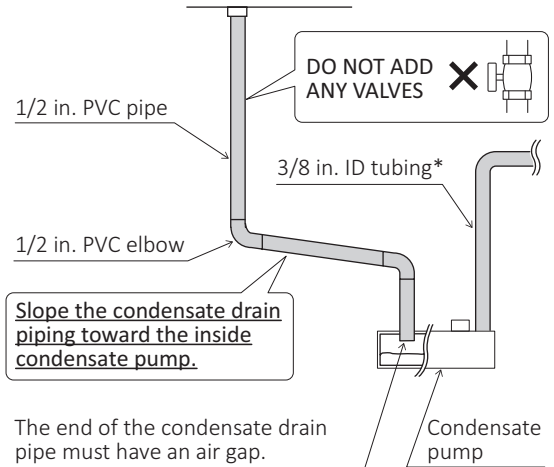

* Install tubing according to the pump manufacturer's instructions.

Condensate Drain Piping

Make the condensate drain piping as short as possible.

NOTE Do not make a trap.

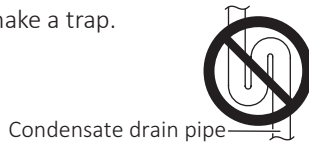

If an external neutralizer is installed

The neutralizing agent needs to be replaced periodically. Refer to the instructions supplied with the neutralizer for suggested replacement intervals.

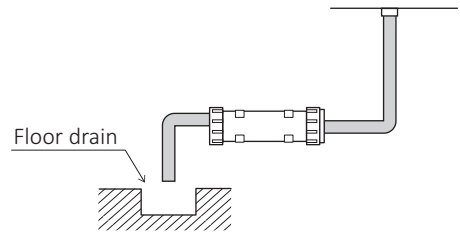

Condensate Drain Piping to Floor Drain

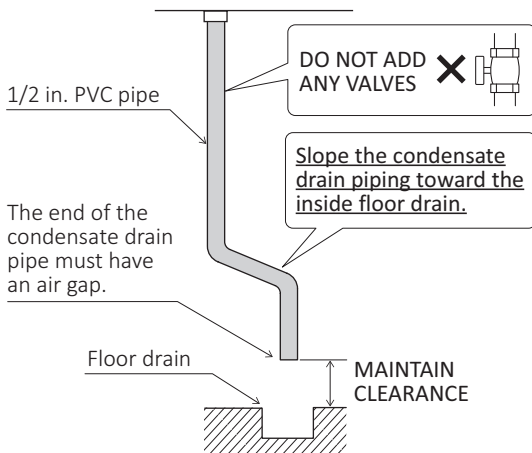

After Installing the Condensate Drain Piping

- Make sure that there are no obstructions blocking the condensate drain line from discharging condensate.
- Make sure that condensate is freely flowing from the condensate drain piping. Condensate will begin flowing out of the water heater within 15 minutes after beginning to operate the water heater.

Freeze Prevention

Take measures to prevent the condensate drain lines from freezing (insulation, heat tape, electric heater, etc.).

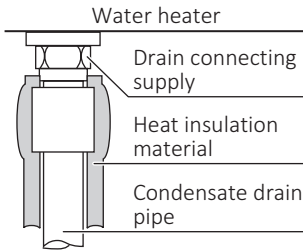

10 Connecting Electricity

Consult a qualified electrician for the electrical work.

10.1 Water Heater

This appliance must be electrically grounded in accordance with local codes, or in the absence of local codes, with the National Electrical Code, ANSI/NFPA 70. In Canada, use the CSA C22.1 Electrical Code (latest edition).

⚠ WARNING

Electrical shock hazard

Do not connect the electrical power to the appliance until all electrical wiring has been completed. Doing so may result in death or serious injury from electrical shock.

⚠ CAUTION

- Label all wires prior to disconnection when servicing controls. Wiring errors can cause improper and dangerous operation. Verify proper operation after servicing.
- Electrostatic discharge can affect electronic components. Take precautions to prevent electrostatic discharges from personnel or hand tools during the water heater installation and servicing to protect its electronic control functions.

Power Supply

- The water heater must be supplied with 120 VAC electric power at 60 Hz. The power consumption may be up to 222 W, or even greater if using optional accessories. Use a circuit that can handle that load.
- Tie the excess power cord outside the water heater. Putting the excess length of cord

inside the water heater may cause electrical interference and faulty operation.

- When using a recirculation pump, remove air from the recirculation line and recirculation pump before connecting the electrical power.

- NOTE**
- Do not let the power cord contact the gas piping.
 - Do not disconnect the electrical power when the water heater is not in use. When the power is off, the freeze prevention function of the water heater will not activate, resulting in possible freezing damage.

Ground

- To prevent electrical shock, provide a ground with resistance less than 100 Ω . An electrician should do this work.
- A grounding screw is provided on the back of the junction box.

- NOTE**
- Do not connect the ground to the city water or gas piping.
 - Do not tie the ground to a telephone line.

Procedure to Connect the Ground and the Power Cord

1. Remove the cover of the junction box (1 screw).
2. Connect the grounding wire to the grounding screw of the junction box.
3. Crimp the outdoor power cord to the power cord of the water heater.
4. Reattach the cover of the junction box (1 screw).

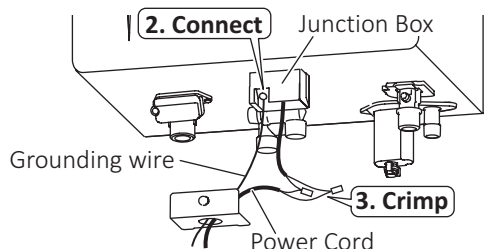

Breaker Installation

Mount a device that shuts off the electrical path automatically (leakage breaker) when electrical leakage is detected.

10.2 Remote Controller (When connecting a remote controller)

- The remote controller is sold separately.
- Install the remote controller refer to the instruction manual provided with the remote controller.
- Only one remote controller can be connected to the water heater.
A malfunction may occur if two or more remote controllers are connected.
- Install according to the National Electrical Code and all applicable local codes.
- The remote controller cord can be extended up to 300 ft (91 m) by splicing the cord and using 18 AWG wire to extend the cord to the appropriate length.
- Use a Y-shaped terminal with a plastic sleeve. Without the sleeve, the copper wire may corrode and cause communication problems.

- NOTE**
- Do not connect the electrical power to the water heater until installation of the remote controller is complete.
 - Be sure to hand tighten when screwing to the terminal block. Power tools may cause damage to the terminal block.

Connecting the Remote Controller Cord

1. Check to make sure that the remote controller cord is of a length sufficient to reach the external connection terminal block.
2. Make sure the electrical power is disconnected from the water heater.
3. Remove the screw securing the terminal block cover and remove the cover.

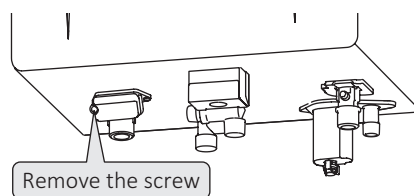

4. Pass the remote controller cord through the wiring throughway. Connect the Y-shaped terminals at the end of the remote controller cord to the terminal block.

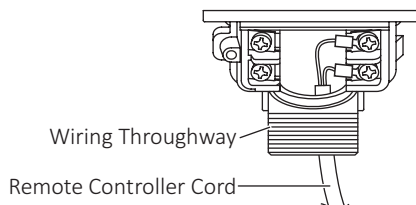

NOTE Tie the excess cord outside the water heater. Do not put the extra length inside the water heater.

5. Reattach the terminal block cover.

10.3 Recirculation Pump

Set the recirculation mode setting to “Always On” or “Manual Timer”. For how to configure the settings, see page 47 when using the operation panel, or see page 50 when using the app.

NOTE This feature is not available when using the quick connect multi-system feature.

Connecting the Pump Control Wire

When using Noritz Recirculation System (RPK-EXT-P)

1. Make sure the electrical power is disconnected from the water heater.
2. Remove the front cover.
3. The pump comes pre-assembled with a wiring harness to enable easy connection to the water heater. Feed wiring through the wiring throughway located at the bottom of the water heater.
4. Locate the connector on pump control wire tag marked “PUMP”. Insert the pump power cord and connect it to the connector.

NOTE A dummy plug is inserted at the factory. This connector must be removed before connecting the pump power cord.

5. Connect the ground wire (green color wire) to the screw at the base of the water heater.
6. Reattach the front cover.

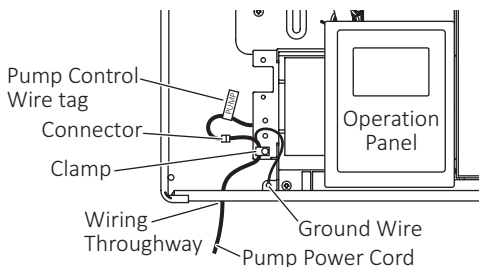

When not using Noritz Recirculation System (RPK-EXT-P)

1. Make sure the electrical power is disconnected from the water heater.
2. Remove the front cover.
3. Cut off the connector at the end of the pump control wires.
4. Only when using a pump of 100 W or less, pass the pump power cord through the wiring throughway and connect it to the pump control wires.

This will be the power supply for the pump. If a large pump (greater than 100 W) is being used, use the voltage from these wires as a signal to close a normally open relay. 120 VAC will be supplied through the relay from a power outlet to the pump.

NOTE Leave enough slack so that the pump control wires will stay connected if the water heater is removed from the wall.

5. Connect the ground wire to the screw at the base of the water heater.
6. Reattach the front cover.

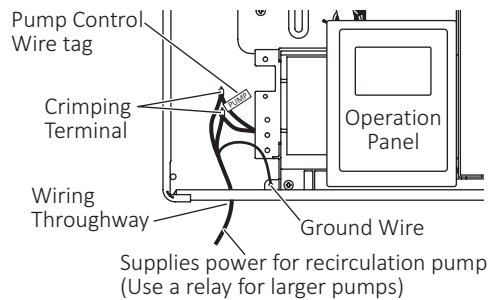

Using a Relay When Connecting Larger Pumps (greater than 100 W)

1. Locate and prepare the pump control wires as in steps 1- 3 for “Connecting the pump control wire”.
2. Choose a suitable installation location for the relay where it will be protected from moisture.
3. Connect the pump control wires from the water heater to the signal input on the relay.
4. Cut one of the electrical supply leads and wire it across the open terminals of the relay.
5. Secure all connections and reattach the front cover.

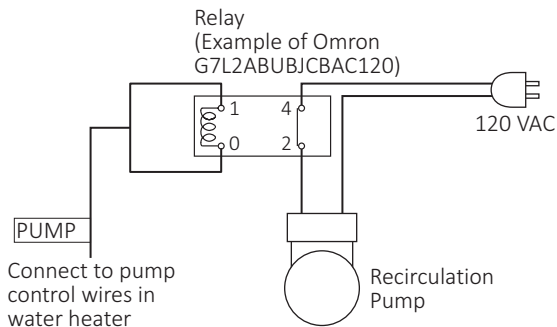

10.4 Quick Connect Cord

NOTE For quick connect (pro) multi-system installation, only use the quick connect cord (part #QC-2, sold separately).

• Quick Connect Type

Unit(s) to be connected	Types
GQ-C**61WZ-1 series	Quick Connect Pro
GQ-C**61WZ series	Quick Connect Pro
GQ-C**60WZ series	Quick Connect
GQ-C**59WZ series	Quick Connect
GHQ-C**01WX series	Quick Connect

• For Quick Connect Pro

- Using “Quick Connect Pro” allows you to connect up to eight water heaters.
- A remote controller is not required. Purchase a remote controller if required.
- Connect “Quick Connect Cord-1” (white tag) to “Quick Connect Cord-2” (red tag). When connecting three or more water heaters, connect “Quick Connect Cord-1” (white tag) and “Quick Connect Cord-2” (red tag) in the same way.
- (When connecting a remote controller) Connect one remote controller to unit #1.

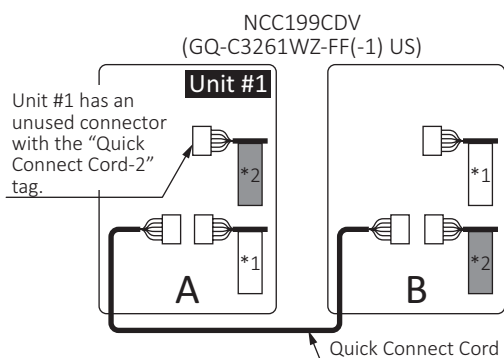

*1 “Quick Connect Cord-1” tag (White)
*2 “Quick Connect Cord-2” tag (Red)

- For Quick Connect
 - Up to two units can be connected.
 - A remote controller is required. Connect the remote controller to this unit. (Do not connect the remote controller to the former NCC series (GQ-C**60WZ series or GQ-C**59WZ series).)
 - A remote controller is not required when connecting the combi boiler (NRCB series [GHQ-C**01WX series]).
 - Connect “Quick Connect Cord-1” (white tag) in this model to “Quick Connect Cord-2” in the former model.

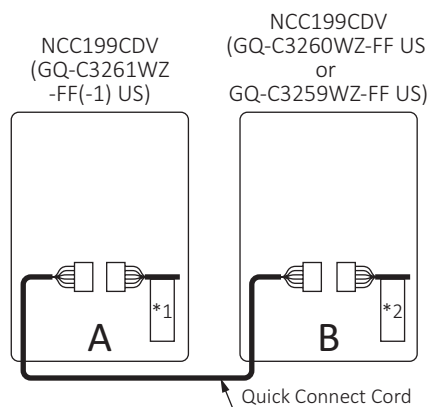

*1 “Quick Connect Cord-1” tag (White)
*2 “Quick Connect Cord-2” tag

- Depending on the water heater to be connected, the “Quick Connect Type” setting needs to be changed.
For how to configure the settings, see page 47 when using the operation panel, or see page 50 when using the app.

Connecting the Quick Connect Cord to Water Heaters

1. Make sure the electrical power is disconnected from the water heater.
 2. Remove the front cover.
 3. Pass the quick connect cord through the wiring throughway and into the water heater.
 4. Plug the connector on the quick connect cord to the connector inside the water heater.
 5. Connect the ground wire (gray wire) to the screw at the base of the water heater.
- NOTE** If the ground wire is not attached, electrical noise may cause mechanical problems.
6. Secure the quick connect cord with a clamp.
 7. Reattach the front cover.

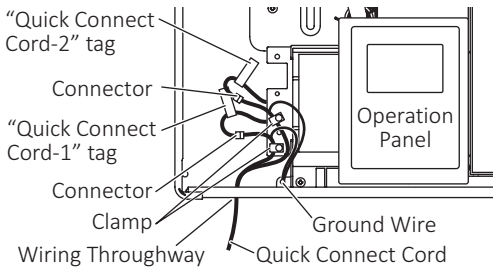

10.5 Condensate Pump Safety Switch Wiring

1. Make sure the electrical power is disconnected from the water heater.
2. Remove the front cover.
3. Cut the wire with the tag marked "Condensate-Pump" and strip the insulation off of the two ends.
4. Pass the wires from the normally closed contact of the condensate pump safety switch through the wiring throughway and connect them to the wire that was cut in step 3. Refer to the manual of the condensate pump.
5. Reattach the front cover.

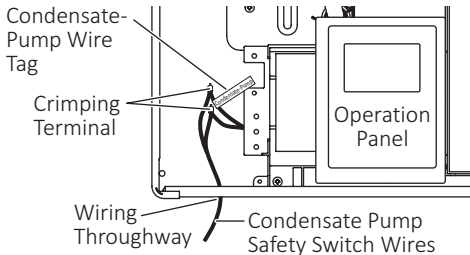

Trial Operation

1. Make sure the electrical power is disconnected from the condensate pump and fill the condensate reservoir with water until the float switch closes the circuit.
2. Connect the electrical power to the water heater.
3. Turn on the power button on the operation panel.
4. Confirm that "External Condensate Pump Triggered 29" appears on the operation panel.
5. Connect the power to the condensate pump and confirm condensate is flowing out of the reservoir.
6. Disconnect the electrical power from the water heater to clear the error code.
7. Wait at least 20 seconds, then reconnect the electrical power to the water heater.

10.6 Carbon Monoxide Detector Wiring

1. Make sure the electrical power is disconnected from the water heater.
2. Remove the front cover.
3. Cut the wire with the tag marked "CO Detector" and strip the insulation off of the two ends.

⚠ DANGER

Do not apply any voltage to the cut wires.

4. Pass the wires from the normally closed contact of the carbon monoxide detector through the wiring throughway and connect them to the wire that was cut in step 3. Refer to the manual of the carbon monoxide detector.
5. Reattach the front cover.

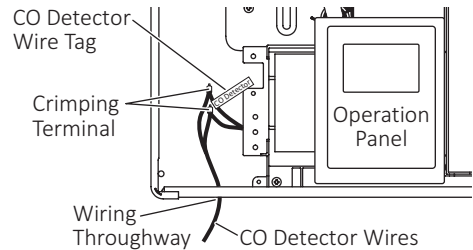

Trial Operation

1. Connect the electrical power to the water heater.
2. Turn on the power button on the operation panel.
3. Enables the test mode of the carbon monoxide detector.
4. Confirm that "External CO Alarm Triggered 13" appears on the operation panel.
5. Disables the test mode of the carbon monoxide detector.
6. Disconnect the electrical power from the water heater to clear the error code.
7. Wait at least 20 seconds, then reconnect the electrical power to the water heater.

11 Water Heater Settings

The remote controller for this water heater is sold separately. You can change the water heater settings with the operation panel or a smartphone app called "EZ Start Plus™" using the built-in Bluetooth®*. A remote controller is not required to configure unit settings. See page 47 when using the operation panel, or see page 50 when using the app.

* Bluetooth®

The Bluetooth® word mark and logos are registered trademarks owned by Bluetooth SIG, Inc. and any use of such marks by NORITZ is under license. Other trademarks and trade names are those of their respective owners.

Canada Regulatory Information

This device complies with Innovation, Science and Economic Development Canada license-exempt RSS standards. Operation is subject to the following two conditions:

- 1) This device may not cause interference.
- 2) This device must accept any interference, including interference that may cause undesired operation of the device.

Le présent appareil est conforme aux CNR Innovation, Sciences et Développement économique Canada applicables aux appareils radio exempts de licence. L'exploitation est autorisée aux deux conditions suivantes :

- 1) l'appareil ne doit pas produire de brouillage;
- 2) l'utilisateur de l'appareil doit accepter tout brouillage radioélectrique subi, même si le brouillage est susceptible d'en compromettre le fonctionnement.

Contains IC: 4389B-EYSHCN
CAN ICES-003(B)/NBM-003(B)

FCC Regulatory Information

This device complies with Part 15 of the FCC Rules. Operation is subject to the following two conditions:

- 1) this device may not cause harmful interference, and
- 2) this device must accept any interference received, including interference that may cause undesired operation.

Contains FCC ID: RYYEYSHCN

⚠ CAUTION

Changes or modifications not expressly approved by the party responsible for compliance could void the user's authority to operate the equipment.

This equipment has been tested and found to comply with the limits for a Class B digital device, pursuant to part 15 of the FCC Rules. These limits are designed to provide reasonable protection against harmful interference in a residential installation. This equipment generates, uses and can radiate radio frequency energy and, if not installed and used in accordance with the instructions, may cause harmful interference to radio communications. However, there is no guarantee that interference will not occur in a particular installation. If this equipment does cause harmful interference to radio or television reception, which can be determined by turning the equipment off and on, the user is encouraged to try to correct the interference by one or more of the following measures:

- Reorient or relocate the receiving antenna.
- Increase the separation between the equipment and receiver.
- Connect the equipment into an outlet on a circuit different from that to which the receiver is connected.
- Consult the dealer or an experienced radio/TV technician for help.

NOTICE

When using a recirculation pump, remove air from the recirculation line and pump before configuring the settings during installation.

11.1 Using the Operation Panel

- The water heater will have limited functionality if settings are not configured during installation.
- When using the app, do not operate the operation panel. See page 50 to configure unit settings.

11.1.1 Operation Panel

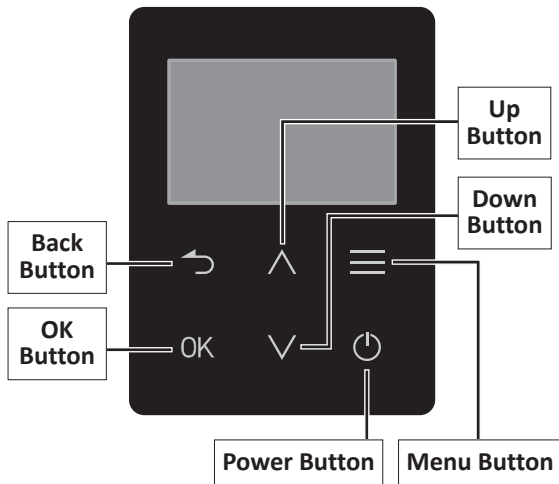

11.1.2 Installation Settings

- NOTE**
- If the unit is actively heating, configuring the settings cannot be completed. Make sure that the unit is not actively heating.
 - The initial screen is automatically displayed only when using the water heater for the first time.
 - If no button on the operation panel is pressed for about 10 minutes during the settings, the change you made will be canceled and the screen will automatically return to the initial screen.
 - Do not press the power button until the settings are complete.

Operation

1. Connect the electrical power to the water heater.
2. <Setting the language>
Use the up or down button to select a value you want to set, then press the OK button.
3. <Switching between 12-hour and 24-hour formats>
Select a value you want to set, then press the OK button.
4. <Setting the clock>
Set the clock, then press the OK button.
5. <Setting the temperature unit>
Convert the temperature unit, then press the OK button.
6. <Configuring the installation settings>
Each item must be set by using the up or down button to select a value, then press the OK button to move to the next setting.

NOTE Settings are not applied in this step, canceling setup at any time during this step will not apply changes.

7. After setting all of the items, use the down button to scroll and review the settings.
8. Once you have finished reviewing all of the settings, follow the instruction on the screen prompting you to press and hold the OK button for 5 seconds.
 - The screen turns off.
 - The settings are not applied unless this operation is performed.

List of Configurable Items

- **Convert Gas Type (See page 31)**
 - **Vent Type (See page 20)**
 - **Vent Size**
Select "2inch" for vent types other than DV and SV.
 - **Vent Length (See page 19)**
Change the setting to Short or Long according the vent length.
 - **Elevation**
 - **Descaling Reminder (See page 39)**
 - **Quick Connect Type (See page 44)**
 - **Recirculation Type**
This is not set for this product.
 - **Recirculation Mode**
Select "Always OFF" when an external recirculation pump is not installed. "Auto Learning" cannot be set for this product.
 - **Operational Mode**
 - **Save settings**
Used to confirm all of the settings.
- NOTE** Settings are not saved until the "Save Settings" steps (steps 7-8) are complete.

To adjust the settings after initial setup

1. Press the up and down buttons at the same time for 5 seconds.
2. Use the up or down button to select a value you want to set, then press the OK button.
 - When changing the installation settings, select "Install Menu".
3. After setting all of the items, use the up or down button to select "Save settings", then press the OK button.
4. Once you have finished reviewing all of the settings, follow the instruction on the screen prompting you to press and hold the OK button for 5 seconds.
 - The screen turns off.
 - The settings are not applied unless this operation is performed.

How to change the language in the Service Menu

1. Press the up and down buttons at the same time for 5 seconds.
2. Use the up or down button to select “Language (Idiomas)” in the “Service Menu (Menu de servicio)”.
3. Select your desired language and press the OK button.

11.1.3 Other Settings

See owner’s guide.

11.2 Using the App “EZ Start Plus®”

11.2.1 Setting Up a Bluetooth Connection on Your Smartphone

Compatible smartphone OS versions

- Operation is not guaranteed on all smartphone models.
- This compatibility information is accurate as of August, 2025. For the latest information, see the EZ Start Plus app information provided by the App Store® or Google Play™.

Android™

- OS 12.0 or later
- Resolution:

	Smartphone	Tablet
Min.	720 × 1,480	800 × 1,280
Max.	1,644 × 3,840	1,600 × 2,560

iPhone®/iPad®

- iOS 17.0 or later
- Resolution:

	Smartphone	Tablet
Min.	750 × 1,334	1,536 × 2,048
Max.	1,320 × 2,868	2,048 × 2,732

Downloading the app



Scan the two-dimensional barcode to download the app from the App Store or Google Play.

- Data charges may apply when you download or update the app.
- The service content, screen design, functions, etc. of the app are subject to change without prior notice.
- Changing the font size on your smartphone does not change the font size on the app.

Connecting via Bluetooth

NOTE When multiple water heaters exist, link all the water heaters and connect the electrical power before connecting to the app.

1. Connect the electrical power to the water heater.
2. Start the EZ Start Plus app.
 - Move to a position within 3 ft (1 m) from the water heater.
3. Check “Contractors, Service Agency, or Gas Supplier.” on the “Installer Authentication Setting” screen.
Enter your company name and location, then tap NEXT.

NOTE This screen is only displayed the first time using the app. To edit, select “Installer Authentication Setting” from the menu.

4. Follow the instructions on the app.
 - Perform the following operations in order.
 - 1) Allow use of Bluetooth.
 - 2) Select the unit you wish to connect to.
 - 3) Locate the 3-digit code on the operation panel.

NOTE

- When a dialog such as “Allow EZ Start Plus to ...” is displayed, select “Allow only while using the app”, “Allow”, etc.
- If a dialog prompting you to use Bluetooth or pair your device is displayed, allow.
- When connecting the same unit again, it is not necessary to enter the 3-digit number.
- (When multiple water heaters are installed)
Select the unit whose name includes #1.

5. Register owner's warranty if needed.
 - You will be redirected to the PROCARD website. Register owner’s warranty there. If you are not a ProCard Member, sign up for the membership before registering owner’s warranty.
 - When you have registered owner’s warranty, close your browser.

NOTE Once you have closed the app and want to connect to the water heater again, wait for at least 30 seconds before reconnecting.

Trademarks

- EZ Start Plus is a trademark of Noritz Corporation.
- iPhone, iPad, and App Store are trademarks of Apple Inc.
- IOS is a trademark or registered trademark of Cisco in the U.S. and other countries and is used under license.
- Android is a trademark of Google LLC.
- Google Play and the Google Play logo are trademarks of Google LLC.

11.2.2 How to Use EZ Start Plus

The app screen may vary by the app version.

<p>Heater Information FAQs Contact Us</p>	<p>Terms of Use Register Warranty App Authentication Setting</p>	<p>Unit Operation History Installer Authentication Setting About Application</p>
--	---	---

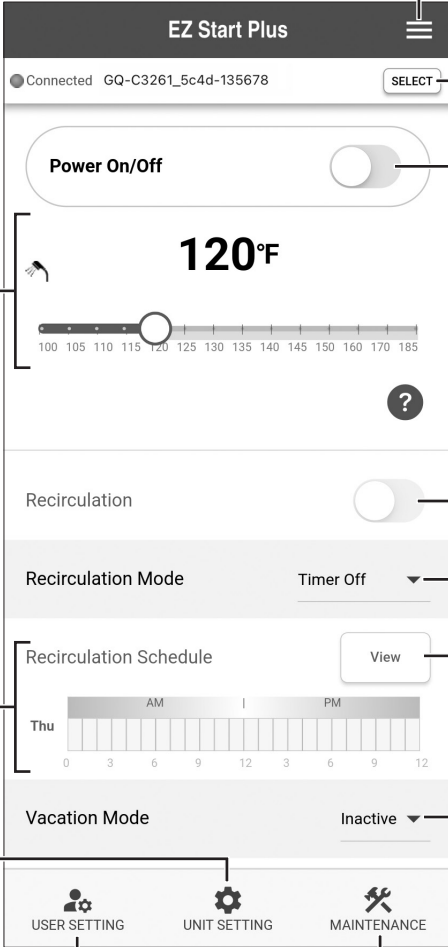

The screenshot shows the EZ Start Plus app interface. At the top, it displays 'EZ Start Plus' and 'Connected GQ-C3261_5c4d-135678'. A 'SELECT' button is in the top right. Below is a 'Power On/Off' toggle switch. A temperature slider is set to 120°F. Below the slider is a 'Recirculation' toggle switch and a 'Recirculation Mode' dropdown menu set to 'Timer Off'. A 'Recirculation Schedule' section shows a weekly schedule for Thursday. At the bottom, there are three tabs: 'USER SETTING', 'UNIT SETTING', and 'MAINTENANCE'. A 'Vacation Mode' dropdown is set to 'Inactive'.

Tap and hold the  symbol and slide it to the desired temperature.

- If you do not tap “Set”, the change you made will be canceled in a few seconds.
- When changing the temperature to 125°F (in °F mode) / 55°C (in °C mode) or higher, you need to change the “Maximum output temp. setting” in the “USER SETTING”.

Tap here to select the water heater to be operated when multiple water heaters are installed.

Turn the water heater operation on/off.

Turn the recirculation operation on/off. This switch can be turned on when the “Power On/Off” switch is “on”.

Select the recirculation timer mode.

Timer Off
Manual Timer

View the recirculation schedule. Can only be edited in Manual Timer mode.

Display on/off schedule.

For changing the settings during installation. (See page 50)
 It is not displayed when “Others (e.g. Owner)” is selected.

Use this setting when you want to suspend recirculation operation (e.g., when leaving for a vacation).

Used only for maintenance.

* This setting can be changed when the “Power On/Off” switch is turned off.

Maximum output temperature setting

Drain Water

Prepares to drain water from the water heater.

Scale Flushing

Used to flush scales caused by hard water. Facilitates the water flow through the water heater supply lines. Stops combustion of the water heater. 1-hour countdown timer is displayed on the water heater. Refer to page 70 for the scale flushing procedure.

NOTE If the language setting on your smartphone is Spanish, the app screen will appear in Spanish.

Temperature setting options

The temperature settings below are examples. The temperature setting necessary depends on the usage, the length of piping and the season.

When using °F mode (Default setting is 120°F)

Fahrenheit (°F)	100	105	110	115	120	125*	130*
	135*	140*	145*	150*	160*	170*	185*

*High temperature
The maximum output temperature can be changed in "USER SETTING".

When using °C mode (Default setting is 50°C (122°F))

Celsius (°C)	37	38	39	40	41	42	43
Fahrenheit (°F)	99	100	102	104	106	108	109

Celsius (°C)	44	45	46	47	48	50	55*
Fahrenheit (°F)	111	113	115	117	118	122	131

Celsius (°C)	60*	65*	70*	75*	80*	85*
Fahrenheit (°F)	140	149	158	167	176	185

*High temperature
The maximum output temperature can be changed in "USER SETTING".

⚠ DANGER

- **To prevent scalding :**
Hot water heater temperatures over 125°F (52°C) can cause severe burns instantly or death from scalding.
- Children, disabled and elderly are at the highest risk of being scalded. Feel water temperature before bathing or showering. Temperature limiting valves are available, consult with installer.
- Take caution when using the water heater again after setting to 125°F (52°C) or higher. Always check the set temperature before use.

- NOTE**
- Consult local codes for minimum operating temperatures.
 - When the hot water temperature is adjusted using thermostatic water mixing valves, set the temperature approximately 20°F (10°C) higher than the required temperature to ensure the appropriate fixture temperature.
 - Noritz recommends that water temperature is set as low as possible to prevent scale build-up in the heat exchanger.

How to use the recirculation menu (Explained in owner's guide)

If you want to suspend recirculation for a vacation or other reasons

Set to "Vacation Mode" (see owner's guide).

NOTE Setting the Power On/Off switch to "off" will stop both the hot water supply and the recirculation system.

If you want to suspend recirculation operation for a while, but want to use hot water

Select "Timer Off" for "Recirculation Mode" and turn off the "Recirculation" switch as well.

To use a water heater with recirculation always on
Use the following settings.

- "Power On/Off" switch: On
 - "Recirculation" switch: On
 - "Recirculation Mode": Timer Off
- * Unlike when "Always On" is set in "UNIT SETTING", the "Recirculation" switch never automatically turns on even when the "Power On/Off" switch is set to "on".

To use a water heater with recirculation always off
Use the following settings.

- "Power On/Off" switch: On
- "Recirculation" switch: Off
- "Recirculation Mode": Timer Off

11.2.3 Using a Smartphone to Configure Settings during Installation

⚠ CAUTION

The settings of your water heater need to be changed according to the installation conditions. Always configure the settings during installation. Using the water heater without configuring the settings may cause a failure or malfunction.

1. Tap "UNIT SETTING".
2. Tap "step 1" to convert the gas type.
For gas conversions, see the installation guide included in the conversion kit to replace the parts correctly.
If the conversion is already completed or there is no need to convert, tap "step 2".
3. Follow the instructions on the app to set the following items in order.

- **Vent Type (See page 20)**
- **Vent Size (DV or SV type only)**
- **Vent Length (See page 19)**
Change the setting to Short or Long according to the vent length.
- **Elevation**
- **Descaling Reminder (See page 39)**
- **Quick Connect Type**
 - **Not Connected:**
For a single water heater
 - **Quick Connect Pro:**
When connecting to the identical model
 - **Quick Connect:**
When connecting to a former model

• **Recirculation Mode**

- **Always Off:**

Set this when NOT USING recirculation or when NOT CONNECTING the pump control wire in the water heater.

“Recirculation” and “Recirculation Mode” on the home screen are not displayed.

- **Always On:**

Set this when connecting the pump control wire in the water heater.

- Recirculation operating is activated by the power supply from the water heater.
- Set “Recirculation Mode” on the home screen to “Timer Off” and operate by turning on or off the “Recirculation” switch.
- The “Recirculation” switch turns on in conjunction with the “Power On/Off” switch on.

- **Manual Timer:**

Manually set hours where recirculation is active.

A schedule can be set for each day of the week with “Recirculation Schedule” on the home screen.

NOTE When the Manual Timer is set by using the operation panel or the remote controller (RC-9018M), the same schedule is set for the entire week.

• **Operational Mode**

- **Standard DHW:**

System does not use a recirculation line.

- **Recirculation:**

System has a recirculation line.

- **Storage Recirculation:**

Supply hot water to a storage tank with a pump(s) recirculating between storage tank and water heaters.

• **Measurement Unit**

4. Make selections for all the setting items, then review the settings and tap “DONE”. If you want to change a setting, tap “BACK” to return to the page that has the item you want to change.

⚠ CAUTION

Before tapping DONE, confirm that the settings are appropriate for the installation conditions, and complete the installation settings.

NOTE To configure the same settings on multiple products, check the “Copy Settings Temporarily” box. The settings are saved for 6 hours, allowing you to use the same settings on other products. Refer to “Configuring the same settings on other identical model”.

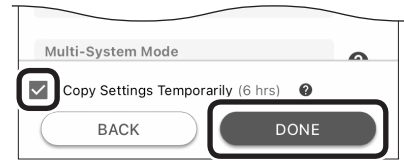

The settings are being sent to the water heater.

- When setup is successful, “Complete” is displayed.
 - If “Error” is displayed, move closer to the water heater and tap “DONE” again.
 - If the unit is actively heating, an error occurs and configuring the settings cannot be completed. Make sure that the unit is not actively heating.
5. Send the setting information to the server by email so that maintenance can be performed promptly when needed. (The email app opens.) Enter;
- your company name (Registered name is listed.),
 - your company location (If registered, the data is listed.),
 - residential (R) or commercial (C), and
 - set temperature you set or you’ll set, then send the email.

Water heater setting is finished.

Tap “BACK” or the home icon to return to the home screen.

Configuring the same settings on other identical model

When multiple water heaters are installed, the same settings can be used for other units.

1. Tap “SELECT” to select the water heater you want to set.

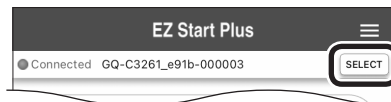

2. Follow the steps in “Connecting via Bluetooth” (see page 48) to connect the water heater to the app.
3. Tap “UNIT SETTING”.
4. Select the installed vent type from the list.

NOTE To use the same settings as the first water heater, the model and vent type must be the same.

5. Tap “Apply Saved Settings”.

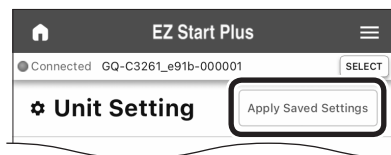

- The saved settings are copied.
6. Review the settings, then tap “DONE”.

⚠ CAUTION

Before tapping DONE, confirm that the settings are appropriate for the installation conditions, and complete the installation settings.

The settings are being sent to the water heater.

- When setup is successful, “Complete” is displayed.
 - If “Error” is displayed, move closer to the water heater and tap “DONE” again.
 - If the unit is actively heating, an error occurs and configuring the settings cannot be completed. Make sure that the unit is not actively heating.
7. Send the setting information to the server by email so that maintenance can be performed promptly when needed. (The email app opens.) Enter;
- your company name (Registered name is listed.),
 - your company location (If registered, the data is listed.),
 - residential (R) or commercial (C), and
 - set temperature you set or you’ll set, then send the email.

Water heater setting is finished.

Tap “BACK” or the home icon to return to the home screen.

Setting Memory (Save frequently used settings)

The settings of the product you are currently connected to can be saved and applied to other products in the same series.

Select the memory you want to use, and then save by choosing “Save the current settings”.

Saved settings cannot be deleted, but can be overwritten.

The saved settings can be used for other products in the identical model (GQ-C3261WZ-1) series, but cannot be used for NCC (GQ-C3261WZ) series or EZ/NRCR series.

12 Trial Operation

The installer should test operate the water heater, explain to the customer how to use the water heater, and give the owner this manual before leaving the installation site.

⚠ DANGER

There is a risk of scalding if the setting temperature is too high.

Should overheating occur, or the gas supply fail to shut off, turn off the manual shutoff valve to the appliance.

- NOTE**
- If installed with a multi-system, refer to the installation manual provided with the system controller (unit).
 - White smoke may be visible from the exhaust vent during cold weather. This is not a malfunction of the water heater.
 - If the water heater does not operate normally, refer to “Troubleshooting” in the owner’s guide.

If air has already been removed from the line, perform step 3 and after.

1. Make sure the electrical power is disconnected from the water heater.
2. Open a hot water fixture to confirm that water is available, and then close the fixture.
 - If air is mixed in the water, run the water for a while.
3. Open the gas supply valve.
4. Check that the electrical power is connected to the water heater and the water heater is turned on.
5. Open a hot water fixture and confirm that the flame indicator on the operation panel comes on and that hot water is being produced.

- NOTE** If error code “11” appears on the operation panel, air may be trapped in the gas line.
- 1) Close a hot water fixture.
 - 2) Turn the water heater off and then back on.
 - 3) Reopen a hot water fixture.

- 4) If necessary, repeat until the air is completely purged from the gas line.

Proceed to steps 7 and 8

If a quick connect multi-system is installed and there is a unit that does not ignite

6. Change ignition priority on the water heaters.

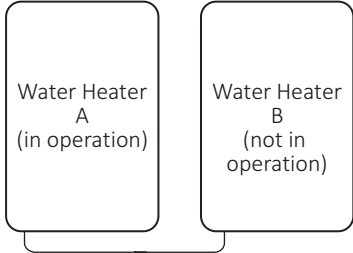

[On water heater B]

- 6-1) Press the up and down buttons at the same time.
 6-2) Use the up or down button to select "Maintenance Menu", then press the OK button.
 6-3) Select "Forced Rotation", then press the OK button.
 6-4) Press and hold the OK button for about 5 seconds.

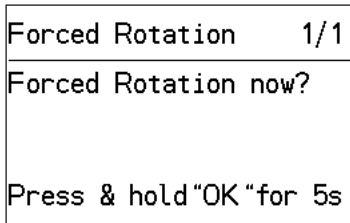

- 6-5) Repeat step 5.

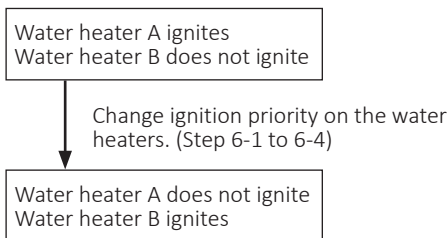

NOTE If step 6 cannot be done, the quick connect cord may not be properly connected. Make sure the cord is properly connected.

Proceed to steps 7 and 8

7. • Make sure that there are no obstructions blocking the condensate drain line from discharging condensate.

- Make sure that condensate is freely flowing from the condensate drain piping. Condensate will begin flowing out of the water heater within 15 minutes after operation has started.

8. After the trial operation, clean the filter in the cold water inlet according to the following procedure.
- 8-1) Close the hot water valve and the water supply valve.
 8-2) With a bucket ready, remove the water drain valve.

NOTE Approximately 0.80 gallons (3.0 L) of water will drain out.

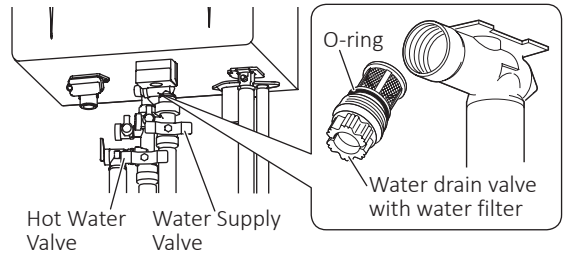

- 8-3) Clean the water filter with a brush under running water.
 8-4) Reattach the water drain valve (with water filter).

NOTE Take care not to lose the o-ring.

- 8-5) Open the hot water valve and the water supply valve. Make sure water does not leak from the water drain valve.

If error codes "11", "121", "122", "90", "901" or "902" appear, check the corresponding items below.

"11": Ignition failure, "121", "122": Flame loss

- Make sure that the gas supply line is appropriately sized.
- Make sure that the gas supply pressure is within the ranges required in this manual.
- Make sure that the gas supply matches the type indicated on the water heater's rating plate or the gas conversion sticker.
- Air may be left in the gas piping. Cycle the power on and off.
- Make sure that all the installation settings are appropriate.

"90", "901", "902": Combustion abnormality

- Make sure that the air supply / exhaust vent is not blocked.
- Make sure that the gas supply pressure is within the ranges required in this manual.
- Make sure that the condensate piping is not frozen or clogged.

- Make sure that the condensate piping is sloped downward.
- Make sure that all the installation settings are appropriate.
- Make sure that a trap is not installed on the condensate drain pipe.

Handling after Trial Operation

- Explain to the customer the “Important Safety Information”, operation procedures and “Follow-up Service” according to the owner’s guide.
- If the water heater will not be used immediately, close off all gas and water shut off valves, drain all of the water out of the water heater and the plumbing system to prevent the water heater and system from freezing, and bleed the gas out of the gas line.
Refer to the procedure for preventing damage from freezing in the owner’s guide.

NOTICE

Freezing is not covered by the Noritz America Limited Warranty.

Lighting Instructions

⚠ WARNING

If the information in these instructions is not followed exactly, a fire or explosion may result causing property damage, personal injury or death.

This water heater does not have a pilot light. It is equipped with an ignition device that automatically lights the burner.

Do not attempt to light the burner by hand.

1. Read the safety information in the installation manual or on the side of the water heater.
2. Turn off all electrical power to the water heater.
3. Turn the gas control manual valve (external to the water heater) clockwise to the off position.
4. Wait five minutes to clear out any gas. If the smell of gas remains, turn off the gas and follow the instructions “Important Safety Information” of the owner’s guide.
5. Turn the gas control manual valve counterclockwise to the on position.
6. Turn on the electrical power to the water heater.

7. The water heater will now operate whenever hot water is demanded. If the water heater will not operate, follow the shutdown instructions and call a service technician.

Shutdown Instructions

1. Stop any water demand.
2. Turn off the electrical power.
3. Turn the gas control manual valve clockwise to the off position.

13 Checklist after Installation

After installing the water heater, review the following checklist. You should be able to answer “Yes” to all of the items in the checklist. If you answer “No” to any item, installation is not complete. Review the appropriate sections to complete the installation. If you have additional questions or need assistance with installation, contact Noritz America at 1-866-766-7489.

Choosing an Installation Location (See page 11)	Yes	No
Make sure that the water heater is not installed in the following places. <ul style="list-style-type: none"> • Places where gasoline, benzene, or adhesives are handled • Places in which corrosive gases (ammonia, chlorine, sulfur, ethylene compounds, acids, etc.) are present in the air • Places where dust or debris will accumulate 		
Installation Clearances (See page 13)	Yes	No
Make sure that the water heater meets the required clearances.		
Installing the Water Heater (See page 15)	Yes	No
Make sure that the condensate container is filled with water.		
Venting the Water Heater (See page 16)	Yes	No
Make sure that required combustion air is supplied to the water heater.		
Make sure that vent materials used are those approved for use with category IV appliances.		
Make sure that there is no leakage or loose connection in the venting system.		
Make sure that the vent length is within that specified in the requirement.		
Make sure the vent termination has bird screen(s) installed.		
Make sure that the termination meets the clearance requirements.		

When using a horizontal section, make sure that the horizontal vent slopes 1/4 in. upwards every 12 in. (300 mm) toward the termination.		
Make sure that the intake pipe and exhaust pipe are properly installed.		
Make sure that the vent system conforms with local codes, state codes, or national codes such as ANSI/NFPA and CSA.		
Connecting the Gas Supply (See page 31)	Yes	No
Make sure that the gas supply matches the type indicated on the water heater’s rating plate or the gas conversion sticker.		
Clean out any debris from the gas piping before connecting the water heater.		
Make sure that the gas piping size is appropriate.		
Make sure that the inlet gas pressure is within the specified range.		
Make sure that there are no leaks from the water heater and its gas connection.		
Connecting the Water Supply (See page 36)	Yes	No
Clean out metal powder, sand, and dirt from the water piping before connecting the water heater.		
Make sure to check and test the water quality to see if water treatment is necessary.		
Make sure that the water supply pressure is 15 to 150 psi (103.4 to 1034 kPa).		
Make sure that there is no water leakage from the cold water supply pipe and the hot water supply pipe.		
Make sure that the pressure relief valve is installed.		
Make sure that the cold water supply line and the hot water supply line are properly connected to the water heater.		
Make sure that appropriate heat insulation measures are taken according to climate of the region. (e.g. wrapping with heat insulation materials, using electric heaters)		
Connecting the Condensate Drain (See page 39)	Yes	No
Make sure that the condensate drain piping is connected.		

Make sure that corrosion resistant material is used for the condensate drain piping.		
Make sure that the size of the condensate drain piping is 1/2 in or larger.		
Make sure that the condensate drain piping slopes towards the inside floor drain or condensate pump.		
Make sure that the end of the condensate drain pipe is open to the atmosphere.		
Make sure that the condensate has been treated before disposal as necessary. (when required by local code or when the condensate could cause damage)		
Make sure that measures are taken to prevent the condensate drain lines from freezing. (e.g. insulation material, heat tape, or electric heater)		
Connecting Electricity (See page 41)	Yes	No
Make sure that the electrical supply is 120 VAC at 60 Hz.		
Make sure the grounding resistance is less than 100 Ω.		
(When connecting a remote controller) Make sure the remote controller cord is correctly installed.		
For installation with a recirculation pump, make sure that the pump is installed by the following method. <ul style="list-style-type: none"> • When using a small pump (100 W or less), connect the pump power cord to the pump control wires. • When using a large pump (greater than 100 W), a relay circuit must be constructed. 		
Water Heater Settings (See page 46)	Yes	No
Make sure that all the installation settings are appropriate.		
Trial Operation (See page 52)	Yes	No
Open a hot water fixture and confirm that the flame mark appears on the operation panel and that hot water comes out of the hot water fixture. When a remote controller is installed, make sure that the BURNER ON indicator or the flame indicator is displayed on the remote controller.		
Clean the filter in the cold water inlet after the trial operation.		

If the water heater will not be used immediately, do the following. <ul style="list-style-type: none"> • Close all gas and water shutoff valves. • Drain all the water in the water heater and the plumbing system. • Disconnect the electrical power to the water heater. 		
Explain to the customer the “Important Safety Information”, operation procedures, and “Follow-up Service” according to the owner’s guide.		
Installation of the Quick Connect Multi-System (See page 59)	Yes	No
(When connecting a remote controller) Make sure that only one remote controller is installed.		
Installation of the Multi-System (See page 62)	Yes	No
Check the installation manual provided with the system controller (sold separately).		

14 Plumbing Applications

Recirculation System

- With a recirculation system, the water from the water heater to the fixtures can be warmed up in advance. This enables you to get hot water to your fixtures more quickly with less waste of water.
- See the owner's guide for more information about how to set up for recirculation operation.
- Scale build-up is more likely to occur in a recirculation system, so it is critically important to have proper water treatment and maintenance.

Isolation Kit

Noritz recommends the use of an isolation kit with the installation. These kits include an integrated shut-off and service valve with unions and a pressure relief valve.

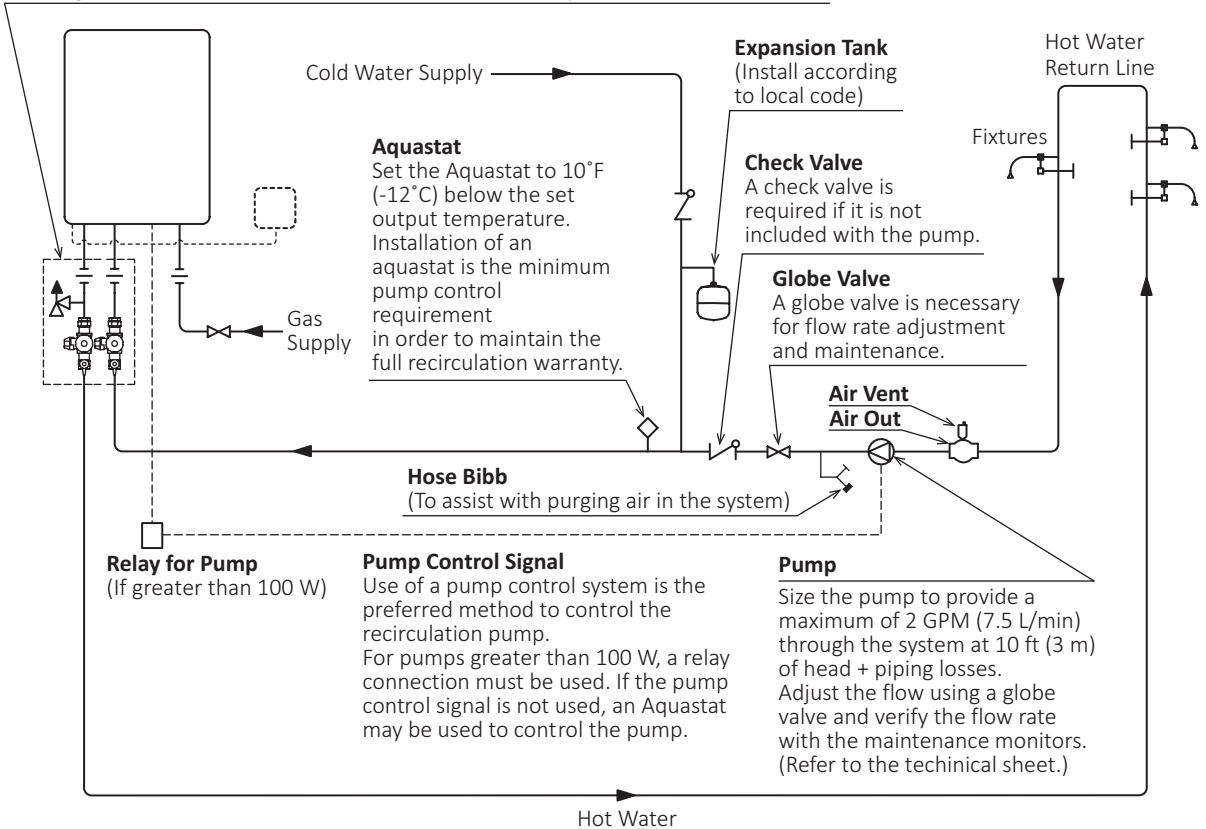

Aquastat Wiring

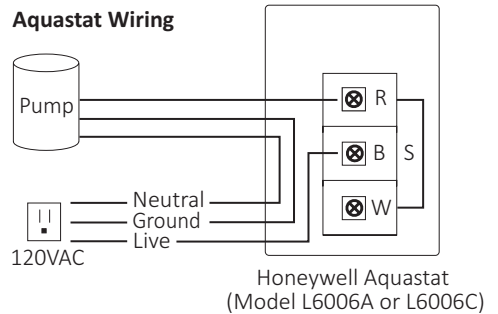

Combination Potable Water and Space Heating System

- The water heater cannot be used for space heating applications only.
- Only POTABLE water may be plumbed through the water heater.

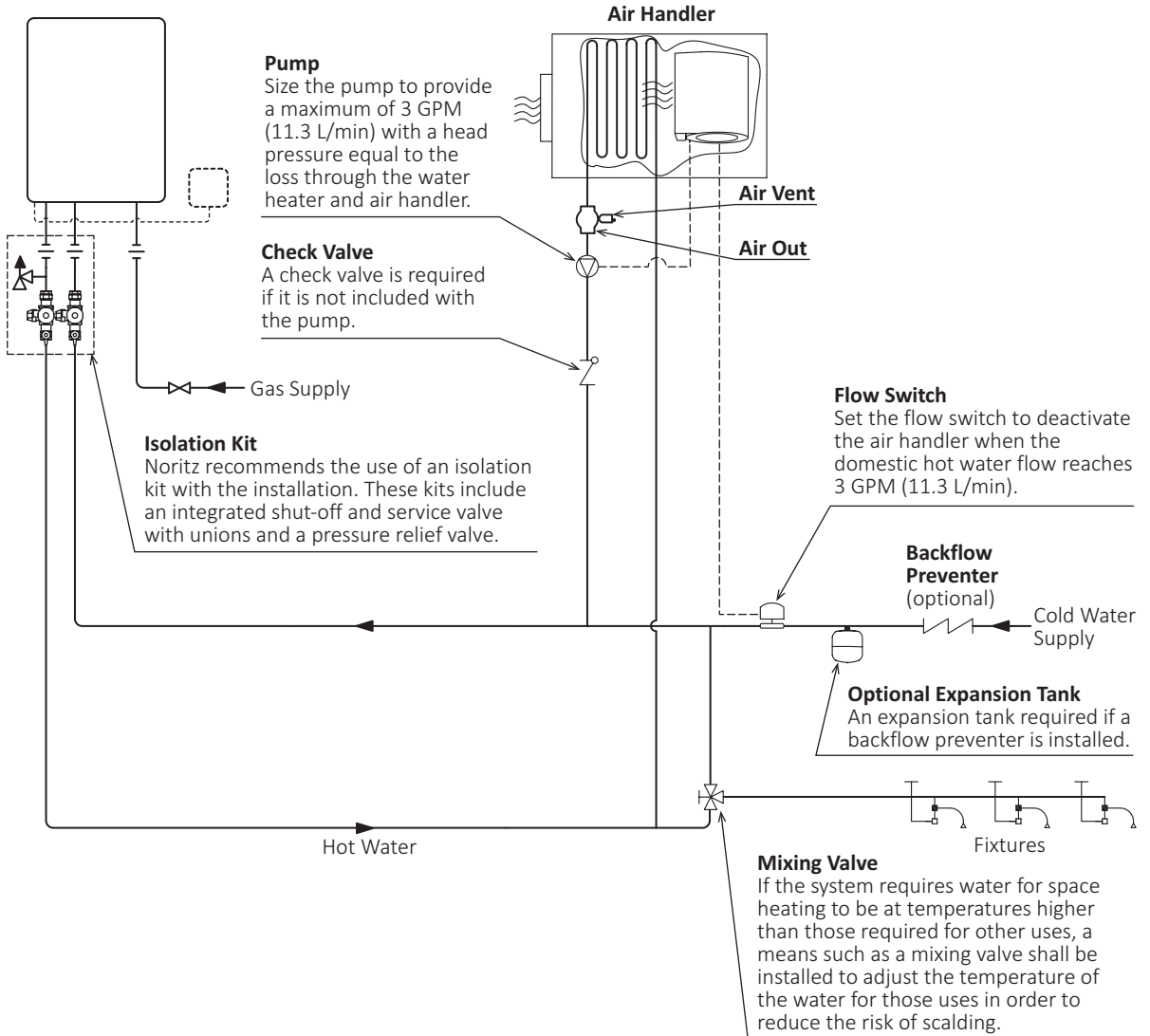

15 Installation of the Quick Connect Multi-System

- There are two types of quick connect multi-systems: “Quick Connect Pro” and “Quick Connect”.
- The quick connect Pro multi-system allows up to eight water heaters to be installed together using only the quick connect cord (part #QC-2, sold separately).
- Water heaters must be identical model: e.g., NCC199CDV connect to NCC199CDV
- Vent type must be same vent type.
- For how to configure the settings, see page 47 when using the operation panel, or see page 50 when using the app.

Quick Connect Pro

- When connecting this unit to a unit of the identical model (GQ-C**61WZ-1 series) or an NCC model unit (GQ-C**61WZ series), use “Quick Connect Pro.”
- Use of a remote controller is optional. Purchase a remote controller if required.
- Set the quick connect setting to “Quick Connect Pro”. Use the operation panel or app to configure the setting.
- (When connecting a remote controller)
Connect one remote controller to unit #1. Unit #1 has an unused connector with the “Quick Connect Cord-2” tag.

Quick Connect

When connecting this unit to a former NCC model (GQ-C**60WZ series or GQ-C**59WZ series) or a combi boiler (NRCB series [GHQ-C**01WX series]), use “Quick Connect”.

Connecting to a Former Model

- A remote controller is required. Connect a remote controller to this unit.
- Set the quick connect setting to “Quick Connect”.
- Once you have replaced a former model with a new model and both units are the new model (GQ-C3261WZ-FF(-1) US), change the quick connect settings for both units to the “Quick Connect Pro” settings.

Connecting to a Combi Boiler

- It is not necessary to connect a remote controller to the water heater.
- Set the quick connect setting to “Quick Connect”.

System Diagram

Refer to page 44 for electrical wiring.

Installation Without a Recirculation System (Standard DHW)

Set “Operational Mode” to “Standard DHW”.

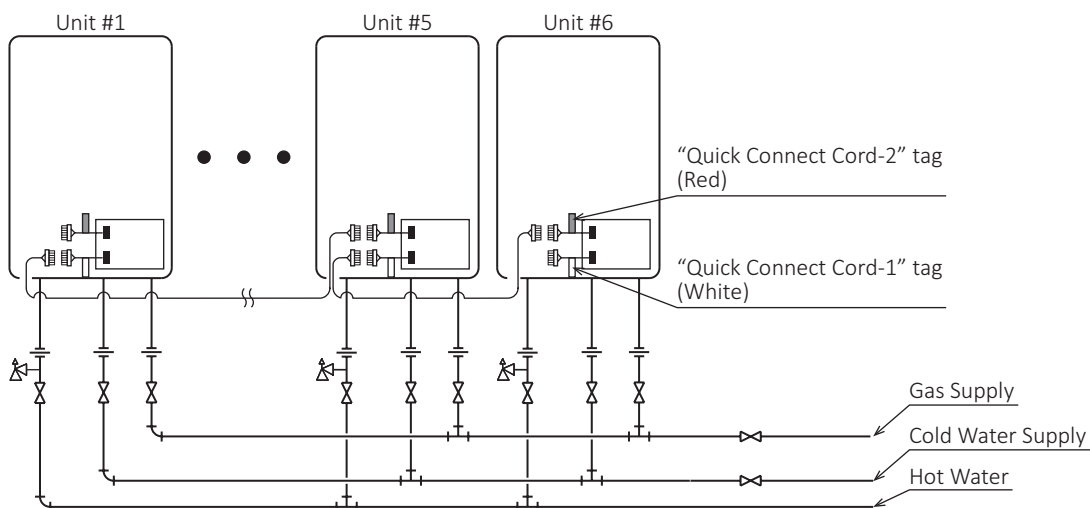

Installation with a Recirculation System

- Set “Operational Mode” to “Recirculation”.
- Install a thermostat or timer within the recirculation system to control the recirculation pump. Water heaters cannot control the recirculation pump. Do not connect the pump control wire in a water heater to the recirculation pump, thermostat, or timer.
- See page 63 for the system diagram.

Installation with a Storage Tank and Recirculation System

- Set “Operational Mode” to “Storage Recirculation”.
- Install a thermostat within the tank recirculation system to control the storage tank recirculation pump. Water heaters cannot control the storage tank and storage tank recirculation pump. Do not connect the pump control wire in a water heater to the recirculation pump or thermostat.
- See page 64 for the system diagram.

Typical Plumbing

Insulate or apply heaters to both the cold water supply piping and the hot water supply piping in order to prevent freezing during cold weather and to prevent heat loss through the piping.

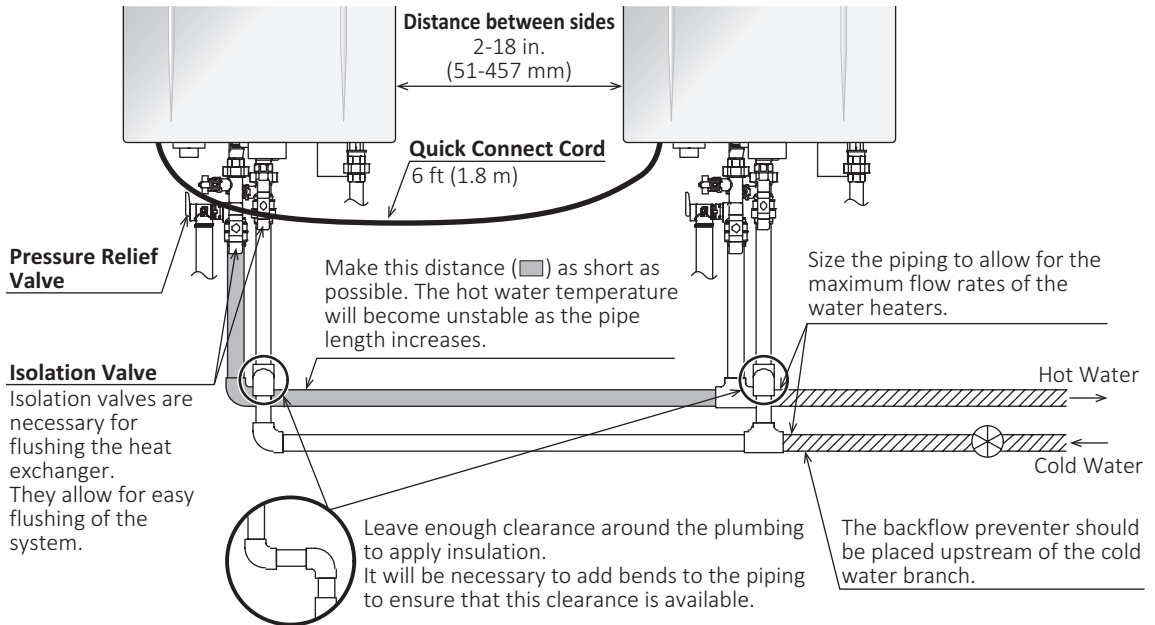

16 Installation of the Multi-System

- For six water heaters or less, use a system controller (SC-401-6M).
For seven water heaters or more, use a system controller unit (SCU-401-12M, SCU-401-24M).
- SC-301-6M (system controller) and SCU-301-12M (system controller unit) are also compatible with the multi-system, but they are not able to use the “Noritz Wireless Adapter (NAW-1)”.
- Refer to the installation manual of the system controller or system controller unit for more information on construction and setting.

16.1 With a System Controller (SC-401-6M)

16.1.1 Example of Installation without a Recirculation System

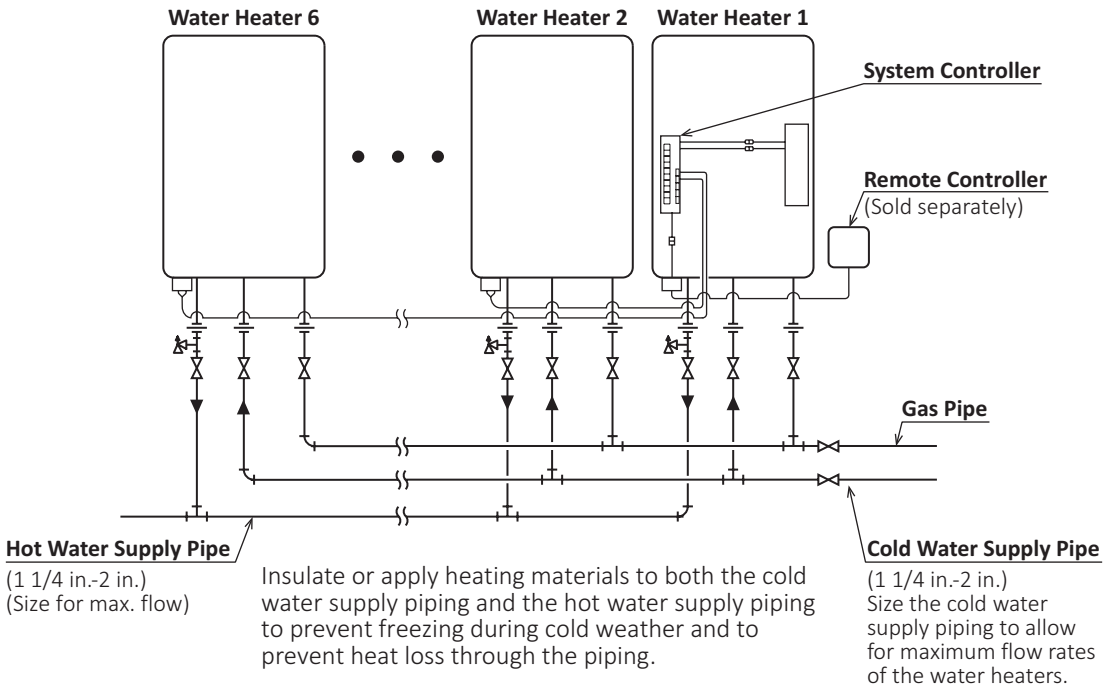

16.1.2 Example of Installation with a Recirculation System

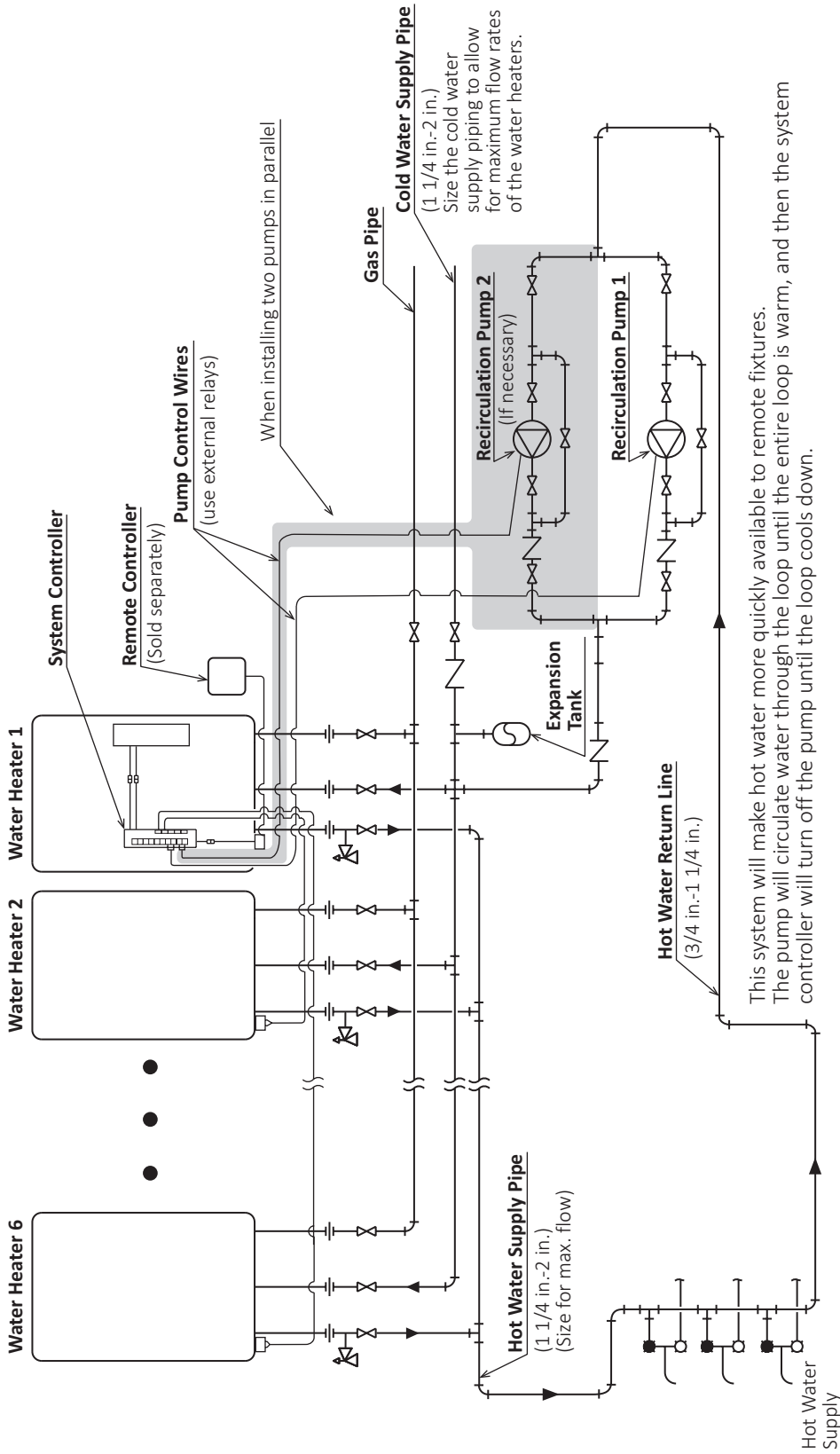

This system will make hot water more quickly available to remote fixtures.

The pump will circulate water through the loop until the entire loop is warm, and then the system controller will turn off the pump until the loop cools down.

- Use copper or stainless steel water piping for the entire system.
- Size the pump to provide at least 2 GPM @ 10 ft of head + piping losses through the system. Check the maintenance monitors on the water heater to make sure the pump is providing adequate flow. (Refer to the technical sheet.)
- Make sure that the flow rate is not greater than 4 ft/sec. (3/4 in. : 5 GPM, 1 1/4 in. : 13 GPM)

NOTE

- if the flow is too low, the recirculation loop temperature will not be warm enough, and if the flow is too high, the lifetime of the water heater will be reduced.
- if there are multiple recirculation loops, try to make the flow rate 0.75-1.25 GPM in each loop.

16.1.3 Example of Installation with a Storage Tank and a Recirculation System (Tank recirculation system)

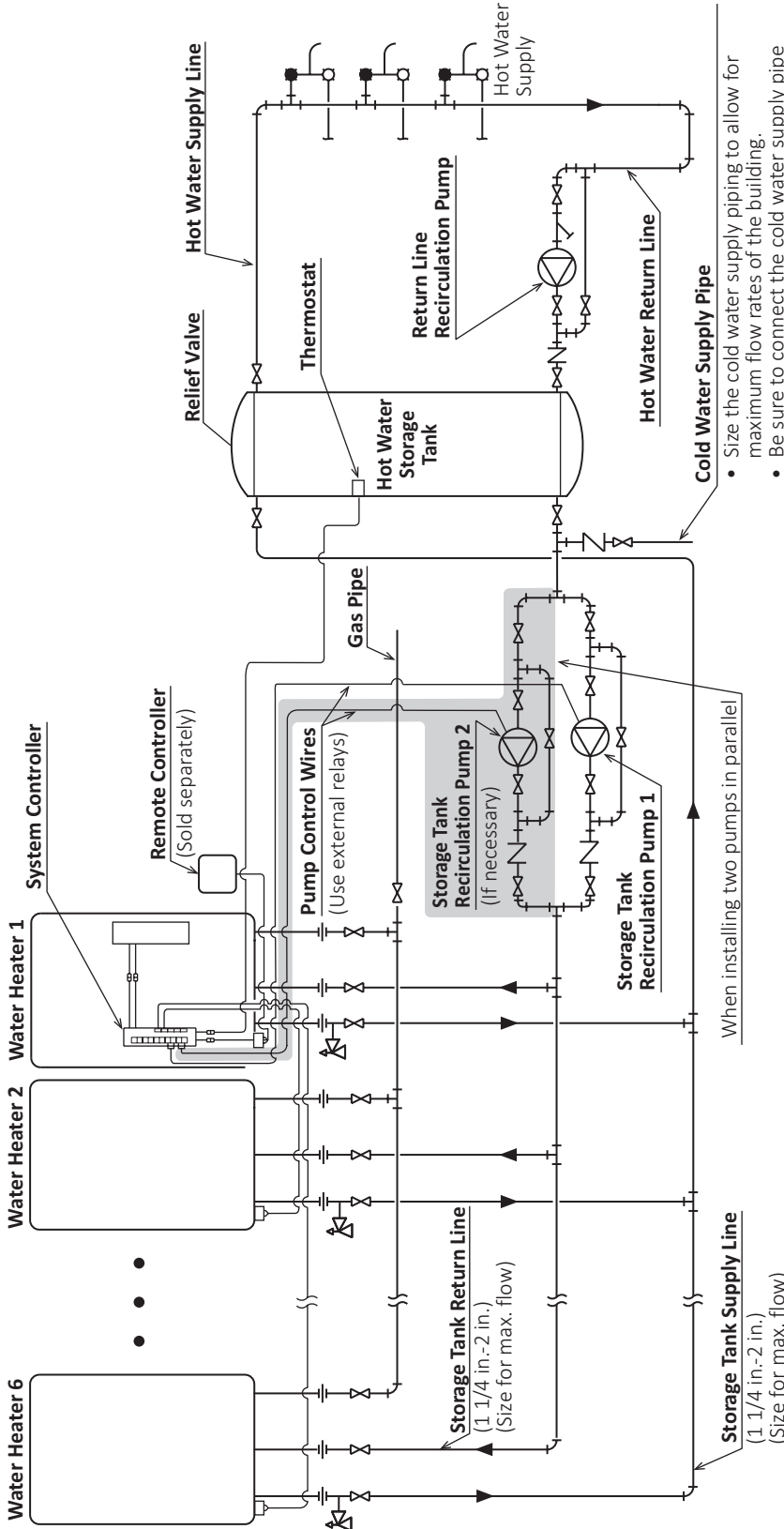

- Size the cold water supply piping to allow for maximum flow rates of the building.
- Be sure to connect the cold water supply pipe between the hot water storage tank and the intake side of the storage tank recirculation pump.

The pump will push water through the multi-system to heat up the tank. When the temperature at the thermostat is high, the system controller will turn off the pump until the loop cools down.

- Use copper or stainless steel water piping for the entire system.
- (When connecting a remote controller)
- For the set temperature of the remote controller, use the temperature (at the thermostat) + about 10°F.
- To maintain maximum performance for the system, the pumps (Storage Tank Recirculation Pump 1,2) shall be selected as the following requirements.

NOTE

- 9 GPM (per water heater) @ 40ft total head + System pressure losses like pipes, valves and fittings.
- Verify that the supply pressure to the water heaters is at least 30 psi.

16.1.4 Multi-System Wiring (Using SC-401-6M)

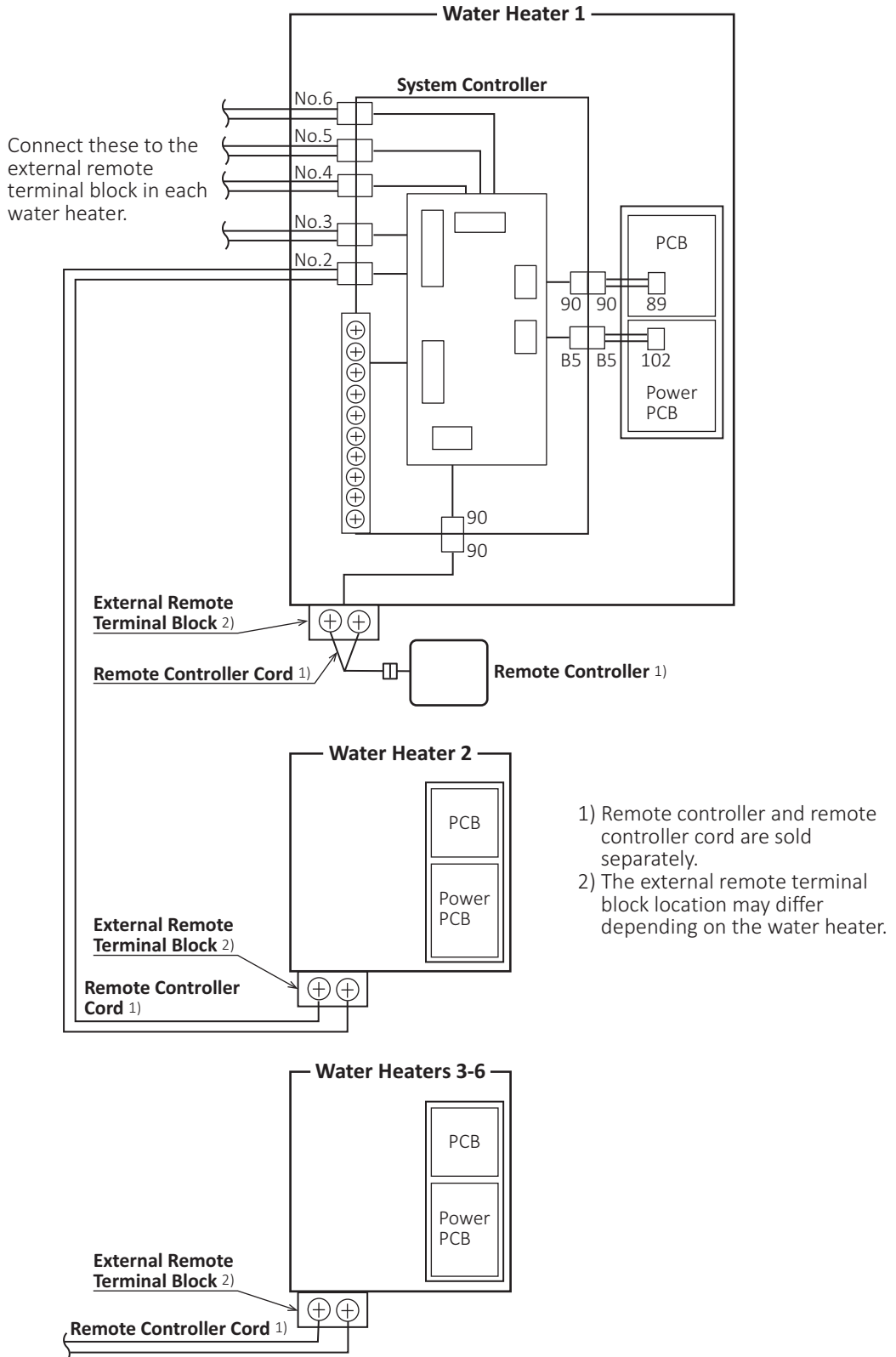

16.2 With a System Controller Unit (SCU-401-12M, SCU-401-24M)

16.2.1 Example of Installation without a Recirculation System (Using a System Controller Unit)

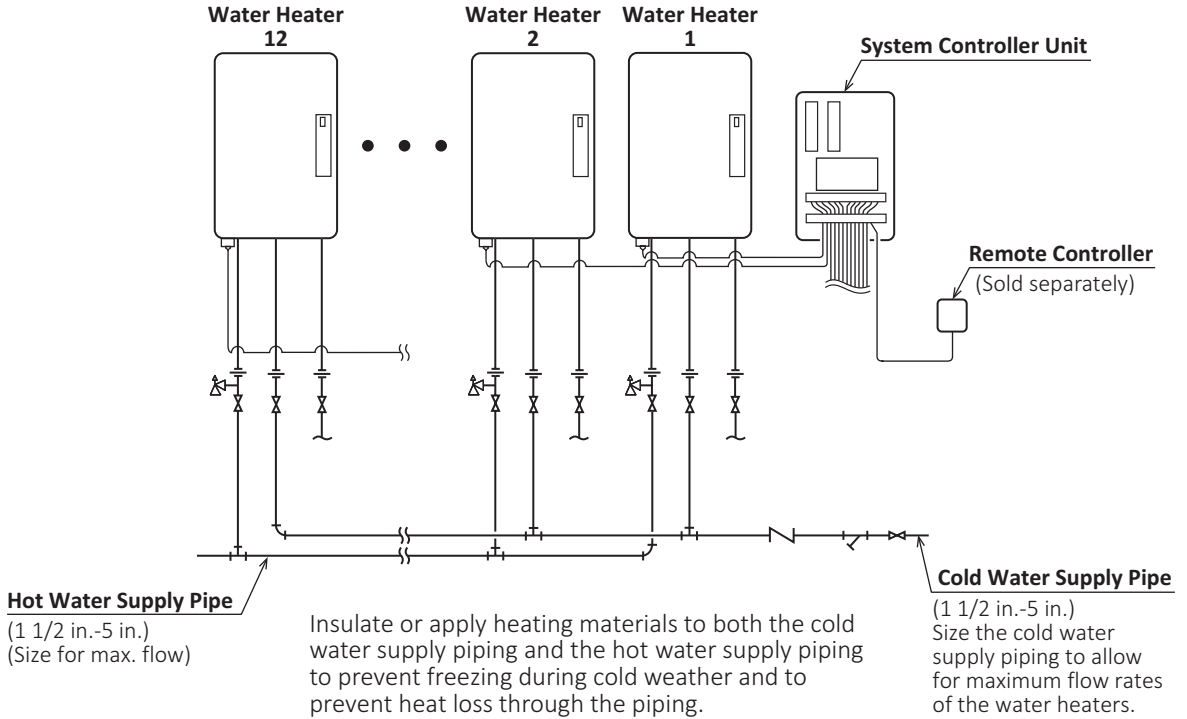

16.2.2 Example of Installation with a Recirculation System (Using a System Controller Unit)

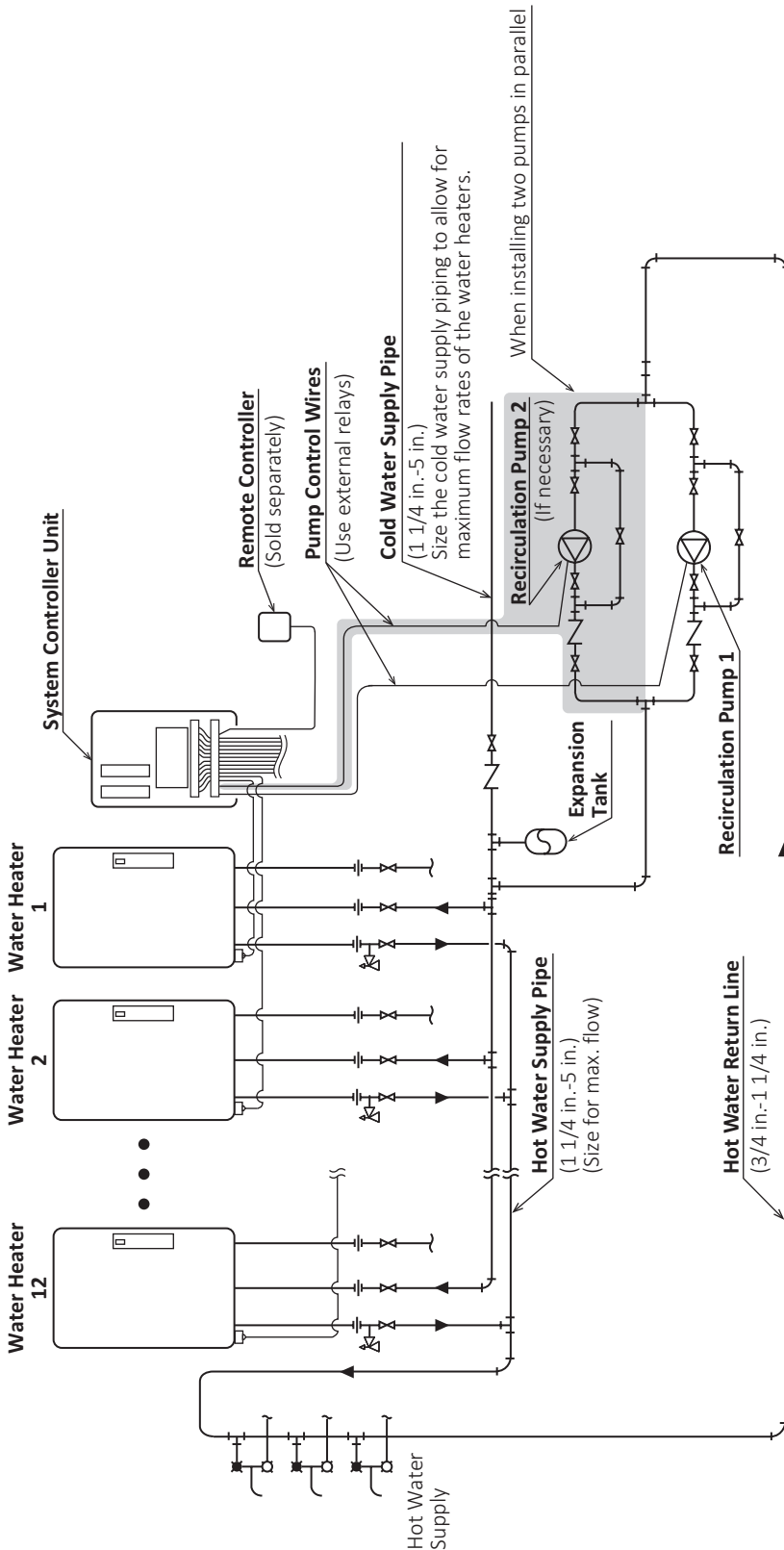

This system will make hot water more quickly available to remote fixtures. The pump will circulate water through the loop until the entire loop is warm, and then the system controller unit will turn off the pump until the loop cools down.

- Use copper or stainless steel water piping for the entire system.
- Size the pump to provide at least 2 GPM @ 10 ft of head + piping losses through the system. Check the maintenance monitors on the water heater to make sure the pump is providing adequate flow (Refer to the technical sheet.).
- Make sure that the flow rate is not greater than 4 ft/sec. (3/4 in. : 5 GPM, 1 1/4 in. : 13 GPM)

- NOTE**
- If the flow is too low, the recirculation loop temperature will not be warm enough, and if the flow is too high, the lifetime of the water heater will be reduced.
 - If there are multiple recirculation loops, try to make the flow rate 0.75-1.25 GPM in each loop.

16.2.3 Example of Installation with a Storage Tank and a Recirculation System (Using a System Controller Unit) (Tank Recirculation System)

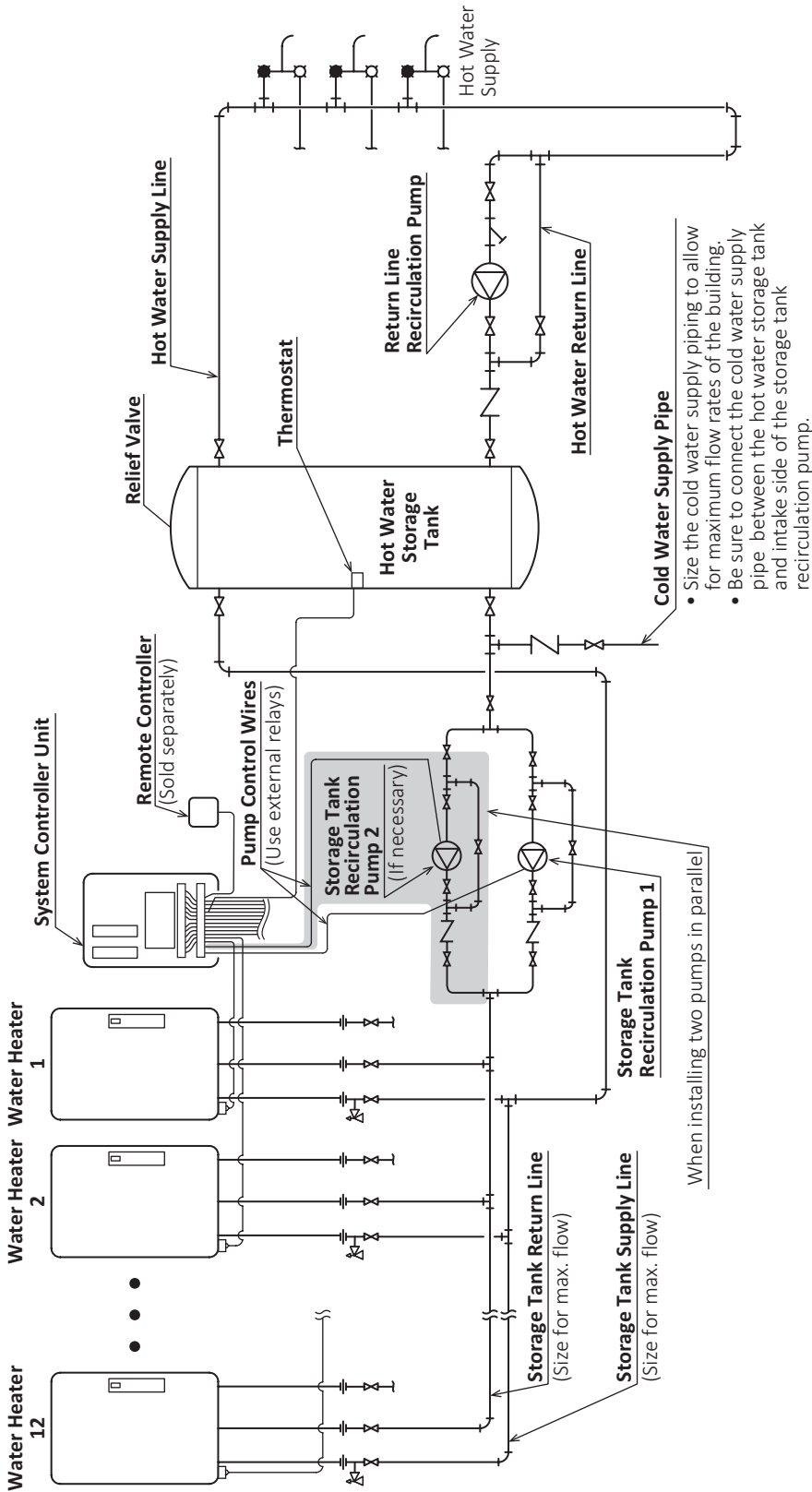

The pump will push water through the multi-system to heat up the tank. When the temperature at the thermostat is high, the system controller unit will turn off the pump until the loop cools down.

- Use copper or stainless steel water piping for the entire system.
- (When connecting a remote controller)
- For the set temperature of the remote controller, use the temperature (at the thermostat) + about 10°F.
- To achieve the highest recovery, size the storage tank recirculation pump for maximum capacity.

- NOTE**
- 9 GPM (each) @ 40 ft of head (160°F setting or less) + piping losses through the system.
 - Verify that the supply pressure to the water heaters is at least 30 psi.

16.2.4 Multi-System Wiring (Using SCU-401-12M, SCU-401-24M)

- The diagram below shows the connection of three water heaters to the system controller unit. When connecting four or more water heaters, follow the same procedure.
- Connect the water heaters to the system controller unit following the detailed wiring instructions included with the system controller unit.
- Always connect a remote controller to the system controller unit.

NOTE Do not connect the included remote controllers to the individual water heaters. These remote controllers will not be used.

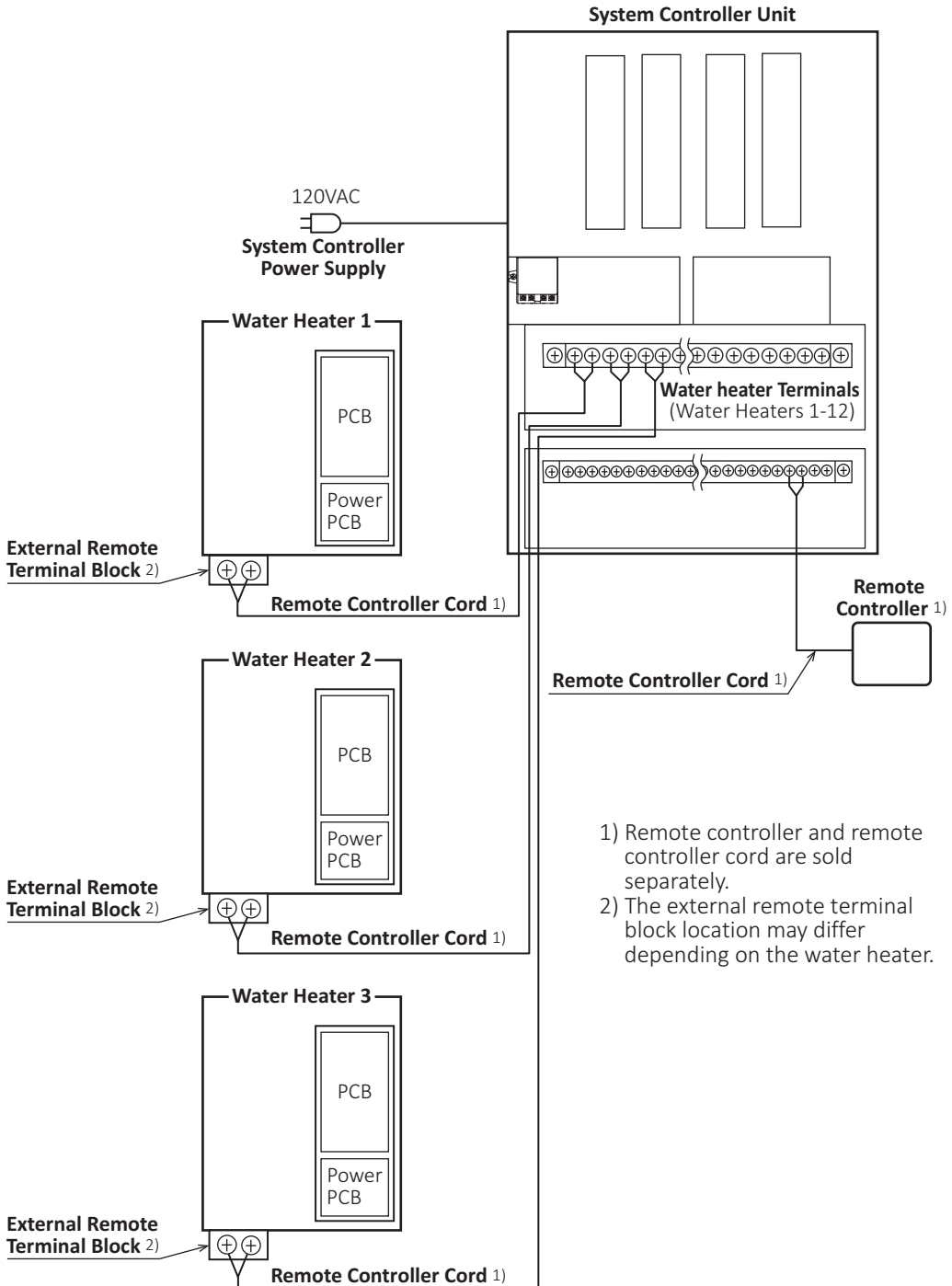

17 Maintenance

17.1 Periodic Check

- Check the following periodically in order to ensure proper operation of the water heater.
- Also check the maintenance items described in the owner's guide.

Venting System

- The venting system must be examined periodically for any leaks or corrosion by a qualified service technician.
- Do not obstruct the flow of combustion and ventilation air.

Burner

- Check the burner flame periodically for a proper blue color and consistency. The burner flame must be blue, clear and stable. Images of normal and abnormal flame are shown in the figures below.
- If the flame does not appear normal, the burner may need to be cleaned by qualified service technician.

Example of Normal Burner Flame

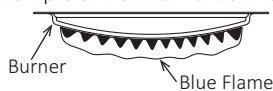

Example of Abnormal Burner Flame

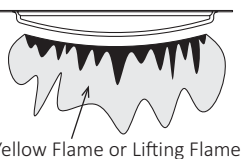

Pressure Relief Valve

- Operate the pressure relief valve once a year to ensure that it is functioning properly and that there is no obstruction. Turn the power off to the water heater before opening the pressure relief valve, and make sure that water draining out of the valve will not cause any damage.
- If the pressure relief valve discharges periodically, it may be due to thermal expansion in a closed

water system. Contact the water supplier or a local plumbing inspector on how to correct this situation. Do not plug the pressure relief valve.

Water Filter

Check and clean the filter inside the cold inlet connection.

NOTICE

If any part of this appliance becomes submerged in water, stop using this appliance. Immediately call a qualified service technician to inspect the appliance and to replace any part of the control system or gas control that has been submerged in water.

17.2 Procedure for Flushing the Heat Exchanger

NOTE This procedure is only intended to be performed by a qualified service professional or authorized Noritz service representative. Any unauthorized performance of this procedure may not be covered by the Noritz America Limited Warranty. Contact Noritz America (1-866-766-7489) for additional support.

If the alarm code "C1#*" is flashing on the operation panel, it means there is scale build-up in the heat exchanger. To prevent damage to the heat exchanger from scale build-up, the heat exchanger needs to be flushed to remove the scale build-up. Damage to the water heater due to scale build-up is not covered by the water heater's warranty.

To clear the alarm code "C1#*", the heat exchanger must be flushed.

If the alarm code "C1#*" is displayed and flashing on the operation panel, contact Noritz America (1-866-766-7489).

* Warning indication, # = 1-9

NOTE The water heater must remain connected to the electrical power when flushing the heat exchanger.

Preparing the Flushing System

1. Close the gas supply valve.
2. Close the water inlet valve (V1) and the water outlet valve (V2).
3. Connect one end of the drain hose (H1) to the drain valve (V3), and then connect the other end to the circulation pump.
4. Connect the drain hose (H2) to the circulation pump.
5. Connect the drain hose (H3) to the drain valve (V4).
6. Pour 1 gallon of “Calcium, Lime and Rust Removal Product” and 1 gallon of water into the bucket.
7. Noritz recommends “Calcium, Lime and Rust Removal Product” for flushing.
8. Place both drain hoses (H2 and H3) into the bucket filled with the flushing solution.

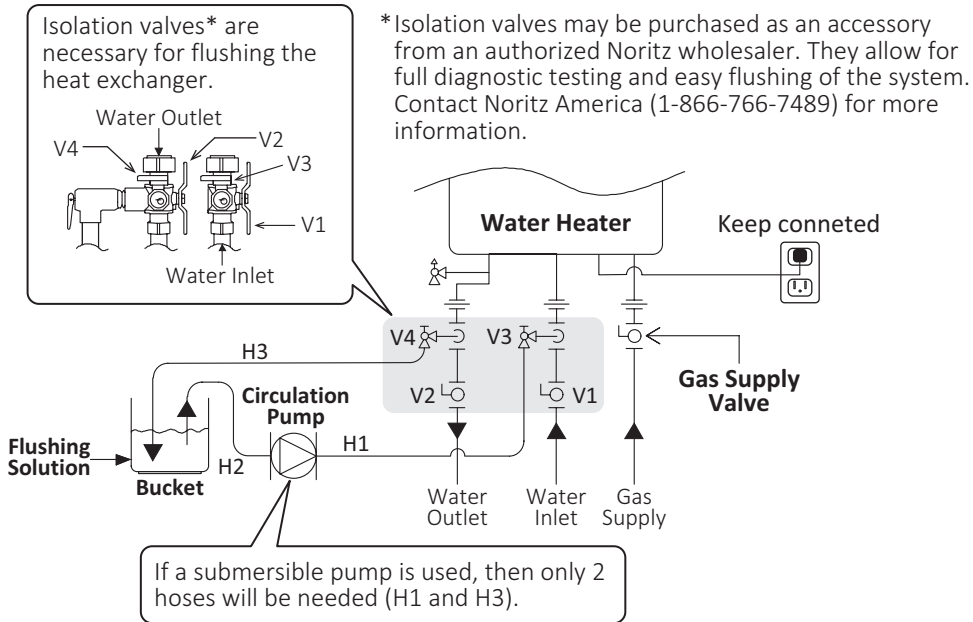

Scale Flushing Procedure

When multiple water heaters are installed, operate on the unit for which you want to flush the heat exchanger, and unit #1 must be cleaned last.

Procedure 1. Flushing the heat exchanger

Using the operation panel

1. Press the menu button.
2. Use the up or down button to select “Scale Flushing”, then press the OK button.
3. Select “Start”, then press the OK button.

Proceed to steps 5 to 8

Using the app

<If a single water heater is installed>

1. Start the app.
2. The “Power On/Off” switch to “off”.
3. Tap “USER SETTING”.
4. Turn the “Scale Flushing” switch on.

Proceed to steps 5 to 8

<If multiple units are installed>

1. Start the app.
2. To switch the water heater to operate, tap “SELECT”.

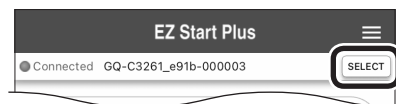

3. Tap “MAINTENANCE”.

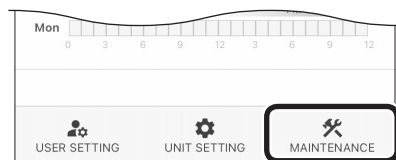

4. Tap “Scale Flushing”. Follow the instructions on the app to complete the procedure.

Proceed to steps 5 to 8

5. Confirm the letters “Scale Flushing in progress [00 min]” are displayed on the operation panel. Also, for a multi-system, “CCC” is displayed on the remote controller and an alarm sounds.
 - Press the “ALARM OFF” button to stop the alarm sound.
 - “System down” is displayed on the remote controller screen when all water heaters in the system are flushed at the same time.
6. Turn on the circulation pump to circulate the flushing solution through the water heater for 1 hour at a rate of 1.5 GPM or more.
7. The letters “Scale Flushing in progress [-- min]” changes to “Scale Flushing in progress [60 min]” on the operation panel when the water heater detects sufficient flow of the flushing solution.



When 1 minute passes, the letters “60 min” will change to “59 min” on the operation panel.



When 1 hour passes, the letters “Scale Flushing in progress [00 min]” are displayed on the operation panel.

- NOTE**
- If the displayed code does not change, check to see if hoses (H1) and (H3) are connected in reverse. If reversed, the flow rate of the flushing solution may be less than 1.5 GPM.
 - When multiple units are installed, the value of the unit with the largest countdown timer value is displayed.

8. Turn off the circulation pump.

Procedure 2. Cleaning the heat exchanger

The flushing solution needs to be rinsed and cleaned out of the water heater. The following procedure is for cleaning the residual flushing solution from the water heater after a successful descale.

1. Remove both drain hoses (H2 and H3) from the bucket. Then, place the drain hose (H3) into a sink or outside to drain.
2. Close the drain valve (V3), and then open the water inlet valve (V1). Do not open the water outlet valve (V2).
3. Allow clean water to flow through the water heater for at least 3 minutes. (Sufficient time is required to clean the water heater.)

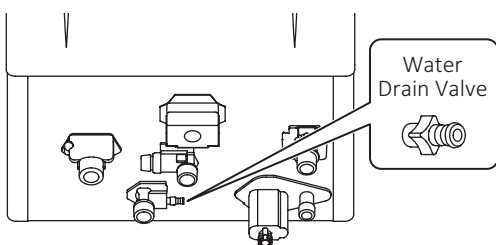

NOTE The water heater has a water drain valve on the bottom of the water heater. Place a bucket under the water heater to drain water from the water drain valve. Carefully unscrew the water drain valve to rinse flushing solution out of the water heater for about 20 seconds, and then close the water drain valve.

4. Close the drain valve (V4), and then remove the drain hose (H3) from the drain valve (V4).
5. Remove the drain hose (H1) from the drain valve (V3).

Using the operation panel

6. Press the up and down buttons at the same time.
7. Use the up or down button to select “Maintenance Menu”, then press the OK button.
8. Select “Scale Flushing”, then press the OK button.

Proceed to steps 9 and 10

Using the app

<If a single water heater is installed>

6. Open the app.
7. Tap “USER SETTING”.
8. Turn the “Scale Flushing” switch off.

Proceed to steps 9 and 10

<If multiple units are installed>

6. Open the app and tap “MAINTENANCE”.
 7. Tap “Scale Flushing”.
- Follow the instructions on the app to complete the procedure.

Proceed to steps 9 and 10

9. Open the gas supply valve and water outlet valve (V2).
10. Confirm that the water heater is operating correctly.